



**Industrial
Climate
Engineering™**
An **ACS** Brand

**CFH3240A/CFH3300A/CFH3360A
(20, 25 & 30 Ton)
Vertical Wall Mount Air Conditioners**



CFH3240 w/Economizer

General Description

Industrial Climate Engineering's CFH air conditioners are used primarily to cool electronic and mechanical equipment shelters (E-Houses). Due to the high internal heat load, these shelters require year-round cooling. ICE air conditioners have the necessary controls and components for operation during these temperatures. All models use next generation non-ozone depleting R-454B refrigerant with a 78% lower GWP than R-410A.

ICE air conditioners are installed on the exterior of the building – no interior space is required. Two openings in the wall allow for the conditioned (supply) air to be discharged into the building and for the indoor air to return to the air conditioner.

A sealed condenser fan motor permits operation in hot, dusty environments.

The direct drive backward inclined motorized impeller evaporator motor provides high aerodynamic efficiency in a compact design. The optimized blade geometry provides excellent air flow at a minimum sound level. Direct drive eliminates all belts and pulleys. A scroll compressor ensures years of dependable service even in the harshest of operating conditions. When outside air is required to provide pressurization, optional fresh air dampers can be field installed in openings in both the left and right side panels. When no outside air is desired, these openings are covered with blank-off panels.

Safety Listed

ICE air conditioners conform to UL/CSA standard 60335-1 and 60335-2-40 and CAN/CSA C22.2, No. 236-2011 Ed.4. The units are tested in accordance to the ASHRAE standard. The air conditioners are commercial and industrial units and are not intended for use in residential applications.



Designed,
Engineered
&
Assembled
In the USA

Features and Benefits

High Efficiency

- Thermal Expansion Valve Improves Efficiency
- High Efficiency Scroll Compressor
- Lanced Fins On the Evaporator and Condenser Coils Improve Heat Transfer

Built-In Reliability

- High and Low Pressure Switch with Lockout
- Adjustable Short Cycle Protection
- Phase Monitor
- High Compressor Temperature Switch
- Internal Motor Overload Protection

Rugged Construction

- Copper Tube, Aluminum Fin Evaporator & Condenser Coil
- Field Or Factory Installed Heaters On Discharge Side of Evaporator Coil
- Baked On Finish Over Galvanneal Steel



Standard Features

Designed for Operation in High and Low Ambient Conditions

- Low ambient control cycles the condenser fan to maintain proper refrigerant pressures.
- Standard on all models, Hot Gas Bypass is typically used to create a false load on the system in low heat load conditions. Hot Gas Bypass is recommended for applications in which the heat load in the space is capable of deviating substantially below the design or if the end user intends on operating the HVAC to maintain low indoor setpoint (typically below 75°F).
- Three minute by-pass of the low pressure switch for start-up of compressor when outdoor temperatures are below 55°F (13°C).
- Designed for operation from 0°F (-8°C) up to 131°F (55°C). Economizer-equipped models can operate in ambient temps as low as -40°F (-40°C).
- A factory installed compressor crankcase heater for operation in low ambient temperatures.

High Efficiency

- Thermal Expansion Valve improves efficiency and cooling capacity at both high and low ambient temperatures.
- High efficiency scroll compressor.
- Lanced fins on the evaporator and condenser coils improve heat transfer.

Ease of Installation

- Sloped top with flashing eliminates need of rainhood.
- Built-in mounting flanges facilitate installation and minimize chance of water leaks.
- Supply and air return openings match many competitive models.
- Factory installed disconnect on all units.
- Single Point Power Entry complies with latest edition of U.L. Standard 60335-2-40.

Built-in Reliability

- High pressure switch and low pressure switch with lockout protects refrigerant circuit.
- Adjustable .03 to ten minute delay on make for short cycle protection.
- Phase Monitor - Continuously measures the voltage of each of the three phases. The monitor separately senses low and high voltage, voltage unbalance including phase loss and phase reversal. A red LED glows to indicate a fault. When all voltages are acceptable, a green LED glows. Automatically resets when voltages and phases are within operating tolerances.
Note: Not required on 1Ø units.
- High temperature switch on the compressor discharge line protects the compressor in the event of a complete loss of refrigerant.
- Internal motor overloads on the evaporator motor, the condenser motor and the compressor.

Remote Alarm Capability

- Dry contacts can be used for remote alarm or notification upon air conditioner lockout.

Rugged Construction

- Copper tube, aluminum fin evaporator & condenser coils.
- Field or factory installed heaters on discharge side of evaporator coil (optional)
- Baked on neutral gray finish over galvanneal steel for maximum cabinet life. (Other finishes are available.)

Ease of Service

- CFH3240/3300/3360 - Stainless steel hinges on the outer side of the two upper panels facilitate access to the control box and the evaporator motor and coil. As an option, these panels can be locked. Stainless steel hinges on the outer side of each lower panel allow access to the compressor compartment.
- Service access valves are standard.
- All major components are readily accessible.
- Front Control Panel allows easy access and complies with NEC clearance codes on redundant side-by-side systems.
- LEDs indicate operational status and fault conditions.

Standard Controls

► Programmable Logic Controller

Standard on all CFH air conditioners, a factory installed Programmable Logic Controller (PLC) controls the operation of the HVAC system. LEDs on the PLC show operational status and provide assistance with diagnosis if troubleshooting is ever required. Various control functions are field selectable and programmable. The PLC is also capable of communicating to other PLCs to allow run time leveling and does not require additional equipment to be installed. The PLC provides improved reliability because of the reduction of components. The components utilized are more durable and the control box wiring has been simplified. Pertinent statistical data about the life of the refrigeration system can be accessed through the PLC.

PLC equipped models include built in head pressure control.

- Advanced PID algorithm to ensure accurate automatic adjustment of condenser airflow.
- Quick-Safe prevention of low and high discharge pressures ensure the system operates well under any conditions.
- Modulating of the condenser fan reduces cycling, improving reliability.
- Energy efficient, achieving the most efficient use of the condenser fan.

The PLC is factory installed and tested, requires no adjustments or changes when the air conditioning system is installed.

Controllers and Thermostats

➤ Thermostats and Controllers for ICE Air Conditioners

See the *Marvair Thermostats and Controllers Product Data Sheet* for the thermostats and controllers for use with Marvair and ICE air conditioners.

Accessories

➤ Supply Grille

CFH3240/3300/3360 P/N 93190
54½" x 15½" (1,384 mm x 394 mm)

➤ Return Grille

CFH3240..... P/N 93191
54½" x 21½" (1,384 mm x 546 mm)
CFH3300/3360 P/N 93192
54½" x 37½" (1,384 mm x 953 mm)

➤ Lifting Eye Kit

CFH3240..... P/N K/40026
CFH3300/3360..... P/N K/40027



Options

ICE CFH air conditioners are designed and built to stringent requirements of electronics shelters, and other applications with special requirements. Numerous options are available to meet these needs.

➤ Protective Coating Packages

Coated Coils: Either the condenser or evaporator coil can be coated. For harsh conditions, e.g., power plants, paper mills or sites where the unit will be exposed to salt water, the coils should be coated. **Note:** Cooling capacity may be reduced by up to 5% on units with coated coils.

Coastal Environmental Package: This package includes:

- Corrosion resistant fasteners,
- Sealed or partially sealed condenser fan motor,
- Insitu coating applied to all exposed internal copper and metal in the in the condenser section, and
- A protective coating on the condenser coil.

All Coat Package: Includes the same features as the Coastal Environmental Package and adds a coating on the evaporator coil and on all exterior and interior components and sheet metal.

Note 1: The insulated internal sheet metal and the internal control box are not coated.

Note 2: The corrosion prevention coating can not be applied to stainless steel.

➤ Dirty Filter Indicator

A factory installed option that measures the difference in pressure across the internal filter and illuminates an LED when the pressure exceeds the desired difference. Dry contacts can be used to remotely monitor filter status.

➤ Lockable Doors

Prevent unauthorized access to internal components and controls.

➤ Dual Compressors With Lead/Lag Operation with Optional Compatible Controller

Dual compressors are standard on the CFH3240/3300/3360. Dual compressor units are factory wired for maximum cooling operation utilizing both compressors. A factory installed jumper can be removed between terminals 1 and 2 of the low voltage terminal strip for 2 stage compressor operation.

➤ Fresh Air Damper

Allows introduction of outside air into the building to provide positive pressure and includes a prefilter. Field installed on the right, left, or both sides of the unit.

Model Number	Fresh Air Damper Part #	Fresh Air Damper Filter Part #	Fresh Air Damper Filter Size In (mm)
CFH3240	K/04757-xxx	92127	91/4" x 37" x 3/8" (235 x 940 x 10)
CFH3300/3360	K/10169-xxx	92526	12" x 26" x 1" (305 x 660 x 25)
xxx designates the color. 200 = Grey (standard). 100 = Beige. 500 = Stainless Steel			

➤ **Cabinet Color**

ICE air conditioners are available in six different cabinet colors. The standard colors are Marvair® beige, white, gray and Carlsbad Canyon (brown). The standard cabinet’s sides, top and front panels are constructed of 20 gauge painted steel. Contact your ICE representative for color chips. Custom colors are also available; contact ICE for details.

Two stainless steel cabinet constructions are available:

Stainless Steel Exterior (Option “5”): This option replaces all standard exterior painted surfaces with stainless steel. This option also replaces the standard unpainted compressor base of the unit and exterior cabinet screws with stainless steel. No other standard construction surfaces are stainless steel in this option, unless listed in this description. Back panel is not stainless steel with this option. This option is designed to give a more economical alternative to full stainless steel, and still offer an enhanced level of protection. For further corrosion protection, please see our “A” offering at full stainless on all metal components.

Stainless Steel Unit (Option “A”): This option replaces all interior and exterior steel sheet metal parts with stainless steel. All galvanized and painted steel surfaces found in the standard unit are stainless steel with this option. All cabinet screws are stainless steel. No other standard construction surfaces are stainless steel, unless listed in this description. This option is designed to give our most robust protection against steel corrosion.

➤ **Filter Access From Return Air Opening (Optional on Select Models)**

Factory or field installed filter bracket allows access to the filters from the return air grille. See model ID, position #20, option code “F”.

➤ **Center Supply/Top Return Configuration**

Location of Supply and Return openings are reversed. See dimensional drawings.

➤ **Economizer**

The factory installed economizer saves energy and reduces the run time on the compressor and condenser fan motor by using outside air to cool the shelter – when ambient conditions are suitable.

On a signal from the wall mounted indoor thermostat that cooling is required, either mechanical cooling with the compressor or free cooling with the economizer is provided. A factory installed enthalpy controller determines whether the outside air is sufficiently cool and dry to be used for cooling. If suitable, the compressor is locked out and the economizer damper opens to bring in outside air through fresh air hoods located on both sides of the air conditioner. The outside air is filtered with prefilters in each of the outside air hoods. Integral pressure relief allows the interior air to exit the shelter, permitting outside air to enter the shelter. The temperature at which the economizer opens is adjustable from 63°F (17°C) at 50% Relative Humidity to 73°F (23°C) at 50% Relative Humidity.

After the enthalpy control has activated and outside air is being brought into the building, the mixed air sensor measures the temperature of the air entering the indoor blower and then modulates the economizer damper to mix the right proportion of cool outside air with warm indoor air to maintain 50°-63°F (10° - 17°C) air being delivered to the building. This prevents shocking the electronic components with cold outside air.

The compressor is not permitted to operate when the economizer is functioning.

If the outside air becomes too hot or humid, the economizer damper closes completely, or to a field selectable minimum open position, and mechanical cooling is activated.

Fresh air hoods with prefilters are field installed on each side of the air conditioner.

➤ **Condenser Coil Dust Protection**

Washable filter protects the condenser coils from dirt and debris.

CFH3240	P/N S/12907-xxx
CFH3300/3360.....	P/N S/12908-xxx
	xxx designates the color

Options for Outside Air for Ventilation

➤ **Configuration “C”: Up to 100% Modulating Economizer**

The economizer reduces the cost of air conditioning by using outside air when acceptable to cool the room (Free Cooling). The factory installed Marvair® economizer has integral pressure relief.

Control Board Logic: Upon a “Call for Cooling”, the economizer control board calculates whether the HVAC operates in economizer mode or mechanical cooling mode based on outdoor temperature (dry bulb) or temperature/humidity (enthalpy). When outdoor conditions are favorable for economizer cooling , the damper drives open and modulates to maintain a 55°F mixed air temperature through the supply grille. When outdoor conditions are not favorable for economizer cooling, the economizer damper remains closed, and the HVAC unit will operate in mechanical cooling mode.

Features Designed for Telecommunication applications:

Hydrogen Fault Input: When 24VAC is applied to the H_FLT input, the economizer board forces the damper to open 100% for emergency ventilation. The compressor does not operate during Hydrogen Fault/Emergency Ventilation. Thermostat must provide the fan “G” signal to HVAC to activate the indoor blower.

Forced Mechanical Cooling: When 24VAC is applied to the FC input of the economizer board, the economizer damper is forced closed, and the HVAC will operate in mechanical cooling mode. This is considered as economizer override in the event economizer cooling is not sufficient for the heat load. Thermostat must provide the fan “G” signal to HVAC to activate the indoor blower.

Economizer Status: The economizer board has contacts that when used with the Marvair CommStat 4 Telecom HVAC Controller, change state to provide feedback to the CommStat 4 to indicate when the HVAC is in economizer mode versus mechanical cooling mode. This feedback allows the CommStat 4 to initiate the forced cooling feature to override economizer cooling and force mechanical cooling.

When used with minimum position potentiometer (optional), the Marvair® economizer can meet requirements of ASHRAE Std. 62.

➤ **Configuration “D”: Two-Position Motorized Fresh Air Damper w/Pressure Relief Ventilation**

Factory Installed Relay Logic: Upon a “Call for indoor blower” via a 24V signal (G), the motorized damper opens to a maximum of 50% of the fully open position. The open position can be decreased from 50% by adjusting the rod position on the drive linkage. In this case, the damper will not open unless there’s a call for the indoor blower.

Note: This circuit does not interrupt the compressor or heater operation.

➤ **Configuration “E”: Two-Position Motorized Fresh Air Damper w/Pressure Relief Ventilation & Independent Control**

Factory Installed Relay Logic: Upon a “Call for Motorized damper” via a 24V signal from an external user-installed device, the motorized damper opens to a maximum of 50% of the fully open position. The open position can be decreased from 50% by adjusting the rod position on the drive linkage.

The motorized damper Does NOT open when there is a call for the indoor fan (G). A 24VAC signal {sourced from LVTB pin 10 and supplied through a user-provided Normally Open (NO) contact} activates (opens) the Motorized Damper and connected Relief Damper. When the 24VAC signal is removed, the Motorized Damper and connected Relief Damper close (spring return).

Note: This circuit does not interrupt the compressor or heater operation.

➤ **Configuration “F”: No Free Cooling, 100%- Damper Opening, Emergency Ventilation Only w/Pressure Relief and Independent Control**

Factory Installed Relay Logic: Upon a “Call for emergency ventilation”, from an external user-provided device; the motorized damper opens to 100% open position and the indoor blower is forced to operate. During “Emergency Ventilation mode”, the compressor and heater do not operate. The relay has a wire lead extended for the installer to connect their emergency ventilation control signal.

Note: This circuit interrupts the compressor and heater operation and forces the indoor blower and damper to operate during emergency ventilation mode.

➤ **Refrigerant Mitigation Board**

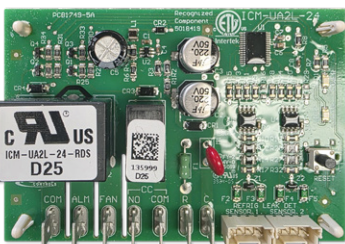

All models in this manual are equipped with a R454B refrigerant leak detection system. Once the unit is installed it must be powered, at all times, except for service. During normal operation the leak detection system has no impact on the operation of the unit, however upon detection of R-454B refrigerant all operations are stopped except for the indoor blower. The unit will then re-circulate air in the room for a minimum of 5 minutes. Once the 5 minutes have expired and the concentration of the refrigerant is below 8 percent of the Lower Flammability Limit (LFL) the unit will be allowed to operate as normal. If the concentration of the refrigerant remains above 8 percent of the LFL the unit will remain in re-circulation mode. To verify actuation of mitigation simply remove

the sensor from the mitigation control board and the system should stop all operation except for the indoor blower. There is no need to calibrate or service the sensor. The sensor will provide an alarm upon failure or end of life. The sensor must be replaced with an identical sensor, or a manufacturer approved alternative.

Minimum Clearances:

Note the minimum clearances required for proper operation and service. Additional clearance is required in high ambient temperatures, greater than 120°F (49°C).

MODEL	MIN. CLEARANCE AROUND SIDES (SINGLE UNIT)	MIN. CLEARANCE BETWEEN UNITS (TWO UNITS)	MIN. SPACE ABOVE UNIT	MIN. CLEARANCE TO FRONT OF UNIT
CFA3240	24 in. (61 cm)	24 in. (61 cm)	24 in. (61 cm)	120 in. (305 cm)
CFA3300/ CFA3360	96 in. (244 cm)	96 in. (244 cm)	24 in. (61 cm)	42 in. (107 cm)

Room Size Limitations

		CFH3240A	CFH3300A	CFH3360A
Minimum Room Size (ft ²)	Top Supply	259.2	424.2	408.4
	Center Supply	508.7	832.4	801.6
Minimum Supply Height (ft)	Top Supply	6.9	6.9	6.9
	Center Supply	3.5	3.5	3.5

Model Identification

Example	C	F	H	3	2	4	0	A	D	0	5	0	D	R	H	+	+	1	C	A	+	A	2	1	+	+	+	+	+	+
Position	1	2	3	4	5	6	7	8	9	10	11	12	13	14	15	16	17	18	19	20	21	22	23	24	25	26	27	28	29	30

1	Unit Designation/Family	C = Industrial Climate Engineering (ICE)
2	Energy Efficiency Ratio (EER)	F = EER <9
3	Refrigerant Type	H = R-454B
4	Compressor Type/Quantity	3 = Dual 7 = 1 Fixed-Speed, 1 Digital (25T & 30T Units Only)
5	Unit Capacity/Nominal	240 = 240,000
6	Cooling (BTUH)	300 = 300,000
7		360 = 360,000
8	System Type	A = Air Conditioner
9	Power Supply (Volts-Hz-Phase)	C = 208/230-60-3 E = 380-50-3 (4 Wire) D = 460-60-3 Z = 575-60-3
10	Heat Designation	
11	@ Rated Voltage	000 = No Heat 150 = 15KW
12	KW = Kilowatt	090 = 9KW 180 = 18KW
13	Ventilation Configuration	A = Solid Front Door C = Economizer D = Motorized Damper w/Pressure Relief E = Motorized Damper w/Pressure Relief & Independent Motorized Damper Control F = No Free Cooling, 100% Emergency Ventilation Only w/Independent Control
14	Dehumidification	R = Electric Reheat T = Electric Reheat w/Humidity Control + = None
15	Controls	H = PLC w/2-Stage Control 2 = PLC w/5-Stage Control + = None \$ = Special
16	Operating Condition	A = Evaporator Freeze Sensor (EFS) Standard on 7.5T & Larger Units C = EFS w/Hot Gas Bypass N = Hard Start P = Hard Start w/Low Ambient & CCH Q = Hard Start w/Low Ambient & Fan Cycle Control (FCC) R = Crank Case Heater (CCH) T = Hard Start w/EFS U = Hard Start w/Hot Gas Bypass V = Hard Start w/Low Ambient & CCH & EFS W = Low Ambient w/CCH X = Hot Gas Bypass Y = Low Ambient w/CCH & FCC Z = Low Ambient w/CCH & EFS 1 = Low Ambient w/FCC 2 = Low Ambient w/FCC & EFS 3 = CCH w/Hot Gas Bypass + = None

17	Indoor Air Quality Features	A = UV Light D = Dry Bulb Sensor E = Dry Bulb Sensor w/Dirty Filter G = Dirty Filter Sensor K = Bi-Polar Ionization + = None
18	Air Flow	1 = Top Supply/Center Return (STD) 2 = Center Supply/Top Return
19	Compressor Location	C = Center
20	Filter Option	A = 2" Pleated (MERV 8, AC/HP-C) C = 2" Charcoal D = MERV 11 High Filtration Package E = MERV 13 High Filtration Package F = Filter Access Through Return Air Opening G = F + C H = F + D J = F + E K = F + W W = Aluminum Washable + = None
21	Corrosion Protection	A = Condenser Coil Only C = Evaporator Coil Only D = Both Coils Condenser & Evaporator E = All Coils Cond/Evap/Reheat F = Coat All K = Coastal Package + = None \$ = Special
22	Engineering	A1 B2
23	Revision Level	A2 C2
24	Cabinet Color	1 = Marvair Beige (STD) 2 = Gray (STD) 3 = Carlsbad Canyon (STD) 4 = White (STD) 5 = Stainless Steel Exterior 9 = Pebble Gray A = Stainless Steel - Unit \$ = Custom Color (Powder Coat)
25	Sound Attenuation	2 = Compressor Blanket + = None
26	Security Option	A = Lockable Access Plate/Tamper Proof B = Lockable Latch/Hinge + = None
27	Fastener/Drain Pan Option	A = Stainless Steel Fasteners C = Stainless Steel Drain Pan D = Stainless Steel Fasteners & Drain Pan F = External Wire Chase Mounting Holes + = None
28	Special Variation	C = Copeland Compressor + = None \$ = Special Configuration Not Covered by Model Nomenclature
29	Unused	+ = None \$ = Special
30	Unused	+ = None \$ = Special

Note: Not all options are available with all configurations. Contact your ICE sales representative for configuration details and feature compatibility.

Capacity Ratings: CFH Air Conditioners (Dual Compressor)

Model Number	CFH3240A				CFH3300A				CFH3360A			
	C	D	E	Z	C	D	E	Z	C	D	E	Z
Cooling BTUH ¹	216,600				300,000				330,000			
Rated Air Flow (CFM ²)	7,400				11,900				10,200			
ESP ³ @ Rated Conditions	0.40				0.45				0.55			
Minimum Air Flow (CFM ²)	5,920				9,520				8,160			

¹Cooling rated at 95°F (35°C) outdoor and 80°F DB/67°F WB (26.5°C DB/19.5°C WB) return air. ²CFM=Cubic Feet per Minute
³ESP=External Static Pressure
Ratings are with no outside air. Performance will be affected by altitude. Ratings are at 230 volts for 208/230 volt units ("A" & "C" models), 460 volts for "D" models, 380 volts for "E" models, and 575 volts for "Z" models.
Derate performance by 17% for "E" (380v 3ø, 50Hz) models.
Operation of units at a different voltage from that of the rating point will affect performance and air flow.

Sensible Total Heat Ratio @ 95°F (35°F) Outside Air Dry Bulb: CFH Air Conditioners (Dual Compressors)

Model Number	CFH3240A				CFH3300A				CFH3360A			
	C	D	E	Z	C	D	E	Z	C	D	E	Z
Total Capacity	216,000				300,000				330,000			
Sensible Heat Ratio	164,629				233,357				258,981			
Sensible Capacity	0.76				0.78				0.78			

Sensible heat ratios based upon outdoor air conditions of 80°F DB/67°F WB (26.5°C DB/19.5°C WB) return air.
Derate performance by 17% for "E" (380v 3ø, 50Hz) models.

SCFM @ Different Static Pressure

Model Number	IWG Static											
	0	0.2	0.4	0.6	0.8	1.0	1.2	1.4	1.6	1.8	2.0	2.2
CFH3240A	8,400	7,892	7,413	6,966	6,545	6,149	5,777	5,427	5,099	4,790	4,500	4,228
CFH3300A	12,269	12,245	11,926	11,604	11,289	11,265	10,651	10,333	10,014	9,695	9,004	N/A
CFH3360A	13,283	12,219	10,934	9,650	8,366	6,766	5,798	4,514	3,230	1,946	662	N/A

¹Operation in the shaded area is not recommended.

Cooling Performance (BTUH) at Various Outdoor Temperatures CFH Air Conditioners (60Hz Power Supply, Dual Compressors)

Model	Return Air DB/WB °F (°C)	Cooling Capacity BTUH	Outdoor Temperature												
			75°F (24°C)	80°F (27°C)	85°F (30°C)	90°F (32°C)	95°F (35°C)	100°F (38°C)	105°F (41°C)	110°F (43°C)	115°F (46°C)	120°F (49°C)	125°F (52°C)	130°F (54°C)	
CFH3240A	72/61 (22/16)	Total	224,208	216,432	208,872	201,096	193,320	185,544	177,768	170,208	166,320	162,432	158,544	154,656	
		Sensible	164,473	161,259	158,154	154,979	151,825	148,690	145,574	142,563	141,022	139,485	137,954	136,426	
	76/63 (24/17)	Total	233,064	225,072	216,864	208,872	200,880	192,888	184,896	176,688	172,800	168,912	165,024	161,136	
		Sensible	178,570	175,376	172,117	168,964	165,831	162,718	159,624	156,466	154,977	153,493	152,013	150,538	
	80/67 (27/19)	Total	250,560	241,920	233,280	224,640	216,000	207,360	198,720	190,080	185,760	181,872	177,984	174,096	
		Sensible	177,370	174,153	170,957	167,783	164,629	161,496	158,383	155,291	153,752	152,372	150,995	149,623	
	84/71 (29/22)	Total	268,056	258,768	249,696	240,408	231,120	221,832	212,544	203,472	198,720	194,832	190,944	187,056	
		Sensible	175,287	172,080	168,968	165,804	162,661	159,539	156,439	153,430	151,863	150,584	149,309	148,037	
	CFH3300A	72/61 (22/16)	Total	311,400	300,600	290,100	279,300	268,500	257,700	246,900	236,400	231,000	225,600	220,200	214,800
			Sensible	232,265	227,878	223,636	219,297	214,982	210,691	206,424	202,299	200,185	198,078	195,976	193,881
76/63 (24/17)		Total	323,700	312,600	301,200	290,100	279,000	267,900	256,800	245,400	240,000	234,600	229,200	223,800	
		Sensible	252,615	248,257	243,807	239,498	235,214	230,954	226,718	222,392	220,352	218,317	216,287	214,263	
80/67 (27/19)		Total	348,000	336,000	324,000	312,000	300,000	288,000	276,000	264,000	258,000	252,600	247,200	241,800	
		Sensible	250,749	246,362	242,002	237,666	233,357	229,072	224,813	220,579	218,471	216,579	214,691	212,809	
84/71 (29/22)		Total	372,300	359,400	346,800	333,900	321,000	308,100	295,200	282,600	276,000	270,600	265,200	259,800	
		Sensible	247,654	243,283	239,039	234,720	230,427	226,160	221,919	217,802	215,655	213,903	212,155	210,412	
CFH3360A		72/61 (22/16)	Total	342,540	330,660	319,110	307,230	295,350	283,470	271,590	260,040	254,100	248,160	242,220	236,280
			Sensible	257,411	252,596	247,940	243,178	238,442	233,731	229,047	224,517	222,196	219,882	217,574	215,273
	76/63 (24/17)	Total	356,070	343,860	331,320	319,110	306,900	294,690	282,480	269,940	264,000	258,060	252,120	246,180	
		Sensible	280,154	275,371	270,487	265,759	261,056	256,380	251,730	246,980	244,739	242,505	240,276	238,054	
	80/67 (27/19)	Total	382,800	369,600	356,400	343,200	330,000	316,800	303,600	290,400	283,800	277,860	271,920	265,980	
		Sensible	278,067	273,254	268,469	263,711	258,981	254,279	249,603	244,954	242,640	240,562	238,490	236,424	
	84/71 (29/22)	Total	409,530	395,340	381,480	367,290	353,100	338,910	324,720	310,860	303,600	297,660	291,720	285,780	
		Sensible	274,629	269,833	265,176	260,436	255,725	251,042	246,387	241,867	239,510	237,586	235,668	233,754	

Cooling Performance (kW/BTUH) at Various Outdoor Temperatures: CFH Air Conditioners (50 Hz Power Supply, Dual Compressors)

Model	Return Air DB/WB °F (°C)	Cooling Capacity kW / BTUH	Outdoor Temperature																								
			75°F (24°C)		80°F (27°C)		85°F (30°C)		90°F (32°C)		95°F (35°C)		100°F (38°C)		105°F (41°C)		110°F (43°C)		115°F (46°C)		120°F (49°C)		125°F (52°C)		130°F (54°C)		
			kW	BTUH	kW	BTUH	kW	BTUH	kW	BTUH	kW	BTUH	kW	BTUH	kW	BTUH	kW	BTUH	kW	BTUH	kW	BTUH	kW	BTUH	kW	BTUH	
CFH3240A	72/61 (22/16)	Total	54.5	186,093	52.6	179,639	50.8	173,364	48.9	166,910	47.0	160,456	45.1	154,002	43.2	147,547	41.4	141,273	40.4	138,046	39.5	134,819	38.6	131,592	37.6	128,364	
		Sensible	40.0	136,513	39.2	133,845	38.5	131,268	37.7	128,633	36.9	126,014	36.2	123,412	35.4	120,826	34.7	118,328	34.3	117,048	33.9	115,773	33.5	114,501	33.2	113,234	
	76/63 (24/17)	Total	56.7	193,443	54.7	186,810	52.7	179,997	50.8	173,364	48.9	166,730	46.9	160,097	45.0	153,464	43.0	146,651	42.0	143,424	41.1	140,197	40.1	136,970	39.2	133,743	
		Sensible	43.4	148,213	42.6	145,562	41.9	142,857	41.1	140,240	40.3	137,640	39.6	135,056	38.8	132,488	38.1	129,867	37.7	128,631	37.3	127,399	37.0	126,171	36.6	124,947	
	80/67 (27/19)	Total	60.9	207,965	58.8	200,794	56.7	193,622	54.6	186,451	52.5	179,280	50.4	172,109	48.3	164,938	46.2	157,766	45.2	154,181	44.2	150,954	43.3	147,727	42.3	144,500	
		Sensible	43.1	147,217	42.4	144,547	41.6	141,895	40.8	139,260	40.0	136,642	39.3	134,042	38.5	131,458	37.8	128,892	37.4	127,614	37.1	126,469	36.7	125,326	36.4	124,187	
	84/71 (29/22)	Total	65.2	222,486	62.9	214,777	60.7	207,248	58.5	199,539	56.2	191,830	53.9	184,121	51.7	176,412	49.5	168,882	48.3	164,938	47.4	161,711	46.4	158,484	45.5	155,256	
		Sensible	42.6	145,488	41.8	142,826	41.1	140,243	40.3	137,617	39.6	135,008	38.8	132,418	38.0	129,844	37.3	127,347	36.9	126,046	36.6	124,985	36.3	123,926	36.0	122,871	
	CFH3300A	72/61 (22/16)	Total	75.7	258,462	73.1	249,498	70.5	240,783	67.9	231,819	65.3	222,855	62.7	213,891	60.0	204,927	57.5	196,212	56.2	191,730	54.9	187,248	53.6	182,766	52.2	178,284
			Sensible	56.5	192,780	55.4	189,139	54.4	185,618	53.3	182,017	52.3	178,435	51.2	174,874	50.2	171,332	49.2	167,908	48.7	166,154	48.2	164,405	47.7	162,660	47.1	160,921
		76/63 (24/17)	Total	78.7	268,671	76.0	259,458	73.2	249,996	70.5	240,783	67.9	231,570	65.2	222,357	62.5	213,144	59.7	203,682	58.4	199,200	57.1	194,718	55.7	190,236	54.4	185,754
			Sensible	61.4	209,671	60.4	206,053	59.3	202,360	58.2	198,784	57.2	195,228	56.2	191,692	55.1	188,176	54.1	184,585	53.6	182,892	53.1	181,203	52.6	179,518	52.1	177,839
80/67 (27/19)		Total	84.6	288,840	81.7	278,880	78.8	268,920	75.9	258,960	73.0	249,000	70.0	239,040	67.1	229,080	64.2	219,120	62.7	214,140	61.4	209,658	60.1	205,176	58.8	200,694	
		Sensible	61.0	208,122	59.9	204,481	58.9	200,861	57.8	197,263	56.8	193,686	55.7	190,130	54.7	186,595	53.6	183,080	53.1	181,331	52.7	179,760	52.2	178,194	51.8	176,632	
84/71 (29/22)		Total	90.5	309,009	87.4	298,302	84.3	287,844	81.2	277,137	78.1	266,430	74.9	255,723	71.8	245,016	68.7	234,558	67.1	229,080	65.8	224,598	64.5	220,116	63.2	215,634	
		Sensible	60.2	205,553	59.2	201,925	58.1	198,402	57.1	194,817	56.0	191,254	55.0	187,713	54.0	184,193	53.0	180,776	52.4	178,993	52.0	177,539	51.6	176,089	51.2	174,642	
CFH3360A		72/61 (22/16)	Total	83.3	284,308	80.4	274,448	77.6	264,861	74.7	255,001	71.8	245,141	68.9	235,280	66.0	225,420	63.2	215,833	61.8	210,903	60.4	205,973	58.9	201,043	57.5	196,112
			Sensible	62.6	213,651	61.4	209,655	60.3	205,791	59.1	201,838	58.0	197,907	56.8	193,997	55.7	190,109	54.6	186,349	54.0	184,423	53.5	182,502	52.9	180,587	52.4	178,676
		76/63 (24/17)	Total	86.6	295,538	83.6	285,404	80.6	274,996	77.6	264,861	74.6	254,727	71.7	244,593	68.7	234,458	65.6	224,050	64.2	219,120	62.8	214,190	61.3	209,260	59.9	204,329
			Sensible	68.1	232,528	67.0	228,558	65.8	224,505	64.6	220,580	63.5	216,677	62.3	212,795	61.2	208,936	60.1	204,993	59.5	203,134	59.0	201,279	58.4	199,429	57.9	197,585
	80/67 (27/19)	Total	93.1	317,724	89.9	306,768	86.7	295,812	83.5	284,856	80.3	273,900	77.0	262,944	73.8	251,988	70.6	241,032	69.0	235,554	67.6	230,624	66.1	225,694	64.7	220,763	
		Sensible	67.6	230,796	66.5	226,801	65.3	222,829	64.1	218,881	63.0	214,955	61.8	211,051	60.7	207,171	59.6	203,312	59.0	201,391	58.5	199,667	58.0	197,947	57.5	196,232	
	84/71 (29/22)	Total	99.6	339,910	96.1	328,132	92.8	316,628	89.3	304,851	85.9	293,073	82.4	281,295	79.0	269,518	75.6	258,014	73.8	251,988	72.4	247,058	70.9	242,128	69.5	237,197	
		Sensible	66.8	227,942	65.6	223,961	64.5	220,096	63.3	216,162	62.2	212,252	61.1	208,365	59.9	204,501	58.8	200,750	58.2	198,793	57.8	197,197	57.3	195,604	56.8	194,016	

Electrical Characteristics - Compressor, Fan & Blower Motors: CFH Air Conditioners (Single and Dual Compressors)

Basic Model	Compressor			Outdoor Fan Motor			Indoor Blower Motor			
	Type	Volts-Hz-Ph	RLA ¹	LRA ²	Volts-Hz-PH	FLA ³	HP ⁴	Volts-Hz-PH	FLA ³	HP ⁴
CFH3240AC	Scroll	208/230-60-3	33.3 (66.6)	255.0	460-60-3	5.5 (11.0)	3 1/2	460-60-3	5.2 (10.4)	4
CFH3300AC		208/230-60-3	45.9 (91.8)	335.5	208/230-60-1	6.3 (25.2)	3/4	460-60-3	5.2 (10.4)	4
CFH3360AC		208/230-60-3	49 (98)	386.3	208/230-60-1	6.3 (25.2)	3/4	460-60-3	5.2 (10.4)	4
CFH3240AD	Scroll	460-60-3	15.4 (30.8)	140.0	460-60-3	5.5 (11.0)	3 1/2	460-60-3	5.2 (10.4)	4
CFH3300AD		460-60-3	20.6 (41.2)	141.0	460-60-1	3.0 (12.0)	3/4	460-60-3	5.2 (10.4)	4
CFH3360AD		460-60-3	24 (48)	182.0	460-60-1	3.0 (12.0)	3/4	460-60-3	5.2 (10.4)	4
CFH3240AE	Scroll	380-50-3	15.4 (30.8)	140.0	400-50-3	5.5 (11.0)	3 1/2	380-50-3	4.3 (8.6)	4
CFH3300AE		380-50-3	20.6 (41.2)	141.0	208/230-50-1	6.3 (25.2)	3/4	380-50-3	4.3 (8.6)	4
CFH3360AE		380-50-3	23.8 (47.6)	186.0	208/230-50-1	6.3 (25.2)	3/4	380-50-3	4.3 (8.6)	4
CFH3240AZ	Scroll	575-60-3	12.9 (25.8)	107.6	460-60-3	5.5 (11.0)	3 1/2	460-60-3	5.2 (10.4)	4
CFH3300AZ		575-60-3	14.5 (29)	109.0	208/230-60-1	6.3 (25.2)	3/4	460-60-3	5.2 (10.4)	4
CFH3360AZ		575-60-3	19.2 (38.4)	131.0	208/230-60-1	6.3 (25.2)	3/4	460-60-3	5.2 (10.4)	4

¹RLA = Rated Load Amps ²LRA = Locked Rotor Amps ³FLA = Full Load Amps ⁴HP = Horsepower
The 575 volt units will have a step down transformer to accommodate the motors.

Summary Electrical Ratings (Wire and Circuit Breaker Sizing): CFH Air Conditioners (Dual Compressors)

Electric Heat		0 kW	0 kW	9.0 kW	9.0 kW	15.0 kW	15.0 kW	18.0 kW	18.0 kW
Basic Model	Volts-Hz-Ph	SPPE ³		SPPE ³		SPPE ³		SPPE ³	
		MCA ¹	MFS ²	MCA ¹	MFS ²	MCA ¹	MFS ²	MCA ¹	MFS ²
CFH3240AC	208/230-60-3	126.1	150	126.1	150	126.1	150	126.1	150
CFH3300AC		160.8	175	160.8	175	160.8	175	160.8	175
CFH3360AC		168.5	200	168.5	200	168.5	200	168.5	200
CFH3240AD	460-60-3	59.9	70	59.9	70	59.9	70	59.9	70
CFH3300AD		73.9	80	73.9	80	73.9	80	73.9	80
CFH3360AD		82.4	100	82.4	100	82.4	100	82.4	100
CFH3240AE	380-50-3	58.1	60	58.1	60	58.1	60	58.1	60
CFH3300AE		70.9	80	70.9	80	70.9	80	70.9	80
CFH3360AE		78.9	90	78.9	90	78.9	90	78.9	90
CFH3240AZ	575-60-3	49.4	50	49.4	50	49.4	50	49.4	50
CFH3300AZ		54.7	60	54.7	60	54.7	60	54.7	60
CFH3360AZ		66.4	80	66.4	80	66.4	80	66.4	80

¹MCA = Minimum Circuit Ampacity (Wiring Size Amps) ²MFS = Maximum Fuse or HACR Breaker Size ³SPPE = Single Point Power Entry
MCA & MFS are calculated at 230 volts on the "A" & "C" models and 460v on the "D" models. This chart should only be used as a guideline for estimating conductor size and overcurrent protection. For the requirements of specific units, always refer to the data label on the unit.

1. MFS (Maximum Fuses Size) value listed is the maximum value as per UL 60335-2-40 calculations for MOCP (branch-circuit conductor sizes in this chart are based on this MOCP). The actual factory installed Overcurrent Protective Device (Circuit Breaker) in the models may be lower than the maximum UL 60335-2-40 allowable MOCP value, but still above the UL 60335-2-40 minimum calculated value or Minimum Circuit Ampacity (MCA) listed.
2. The end user shall size conductors based on the Single Point Power Entry (SPPE) - Minimum Circuit Ampacity. The service circuit breaker shall not be sized less than the minimum circuit ampacity associated to Single Point Power Entry value provided. The service circuit breaker shall also not be sized greater than the Maximum Fuse size associated to the Single Point Power Entry Value Provided.
3. While this electrical data is presented as a guide, it is important to electrically connect properly sized fuses and conductor wires in accordance with the National Electrical Code and all local codes

Summary Electrical Ratings With Electric Re-Heat (Wire and Circuit Breaker Sizing): CFH Air Conditioner (Dual Compressors)

Electric Heat		0 kW	0 kW	9.0 kW	9.0 kW	15.0 kW	15.0 kW	18.0 kW	18.0 kW
Basic Model	Volts-Hz-Ph	SPPE ³		SPPE ³		SPPE ³		SPPE ³	
		MCA ¹	MFS ²	MCA ¹	MFS ²	MCA ¹	MFS ²	MCA ¹	MFS ²
CFH3240AC	208/230-60-3	126.1	150	126.1	150	129.5	150	138.6	150
CFH3300AC		160.8	175	160.8	175	160.8	175	160.8	175
CFH3360AC		168.5	175	168.5	175	168.5	175	168.5	175
CFH3240AD	460-60-3	59.9	60	59.9	60	63.2	70	67.7	70
CFH3300AD		73.9	80	73.9	80	73.9	80	75.2	90
CFH3360AD		82.4	90	82.4	90	82.4	90	82.4	90
CFH3240AE	380-50-3	58.1	60	58.1	60	65.9	70	71.3	80
CFH3300AE		70.9	80	70.9	80	72.2	80	77.6	90
CFH3360AE		78.9	80	78.9	80	78.9	90	81.6	90
CFH3240AZ	575-60-3	49.4	50	49.4	50	52.1	60	55.8	60
CFH3300AZ		54.7	60	54.7	60	55.4	60	59.1	60
CFH3360AZ		66.4	70	66.4	70	66.4	70	66.4	70

¹MCA = Minimum Circuit Ampacity (Wiring Size Amps) ²MFS = Maximum Fuse or HACR Breaker Size ³SPPE = Single Point Power Entry
MCA & MFS are calculated at 230 volts on the "A" & "C" models and 460v on the "D" models. This chart should only be used as a guideline for estimating conductor size and overcurrent protection. For the requirements of specific units, always refer to the data label on the unit.

1. MFS (Maximum Fuses Size) value listed is the maximum value as per UL 60335-2-40 calculations for MOCP (branch-circuit conductor sizes in this chart are based on this MOCP). The actual factory installed Overcurrent Protective Device (Circuit Breaker) in the models may be lower than the maximum UL 60335-2-40 allowable MOCP value, but still above the UL 60335-2-40 minimum calculated value or Minimum Circuit Ampacity (MCA) listed.
2. The end user shall size conductors based on the Single Point Power Entry (SPPE) - Minimum Circuit Ampacity. The service circuit breaker shall not be sized less than the minimum circuit ampacity associated to Single Point Power Entry value provided. The service circuit breaker shall also not be sized greater than the Maximum Fuse size associated to the Single Point Power Entry Value Provided.
3. While this electrical data is presented as a guide, it is important to electrically connect properly sized fuses and conductor wires in accordance with the National Electrical Code and all local codes

Unit Load Amps - CFH Air Conditioners (Dual Compressors)

Basic Model Number	Volts-Hz-Ph	Current Amps		Load of Resistive Heating - Elements Only (Amps)			Total Maximum Heating Amps		
		AC ¹	IBM ²	9 kW	15 kW	18 kW	9 kW	15 kW	18 kW
CFH3240AC	208/230-60-3	109.4	10.4	21.7	36.1	43.3	32.1	46.5	53.7
CFH3300AC		137.8	10.4	21.7	36.1	43.3	32.1	46.5	53.7
CFH3360AC		144	10.4	21.7	36.1	43.3	32.1	46.5	53.7
CFH3240AD	460-60-3	52.2	5.2	10.8	18.0	21.7	16.0	23.2	26.9
CFH3300AD		63.6	5.2	10.8	18.0	21.7	16.0	23.2	26.9
CFH3360AD		70.4	5.2	10.8	18.0	21.7	16.0	23.2	26.9
CFH3240AE	380-50-3	50.4	4.3	13.0	21.7	26.0	17.3	26.0	30.3
CFH3300AE		60.6	4.3	13.0	21.7	26.0	17.3	26.0	30.3
CFH3360AE		67.0	4.3	13.0	21.7	26.0	17.3	26.0	30.3
CFH3240AZ	575-60-3	42.9	4.16	9.0	15.1	18.1	13.2	19.2	22.2
CFH3300AZ		47.4	4.16	9.0	15.1	18.1	13.2	19.2	22.2
CFH3360AZ		56.8	4.16	9.0	15.1	18.1	13.2	19.2	22.2

¹AC = Air Conditioner Unit Amps ²IBM = Indoor Blower Motor
Heating kW is rated at 240 volts on the ACA & ACC models. Derate heater output by 25% for operation at 208 volts. Heating kW is rated at 480 volts on the ACD models. Total heating and cooling amps includes all motors. Three phase models contain single phase motor loads. Loads are not equally balanced on each phase and values shown are maximum phase loads.

Dimensional Data: CFH3240A - Top Supply/Center Return

Engineering Revision "C"

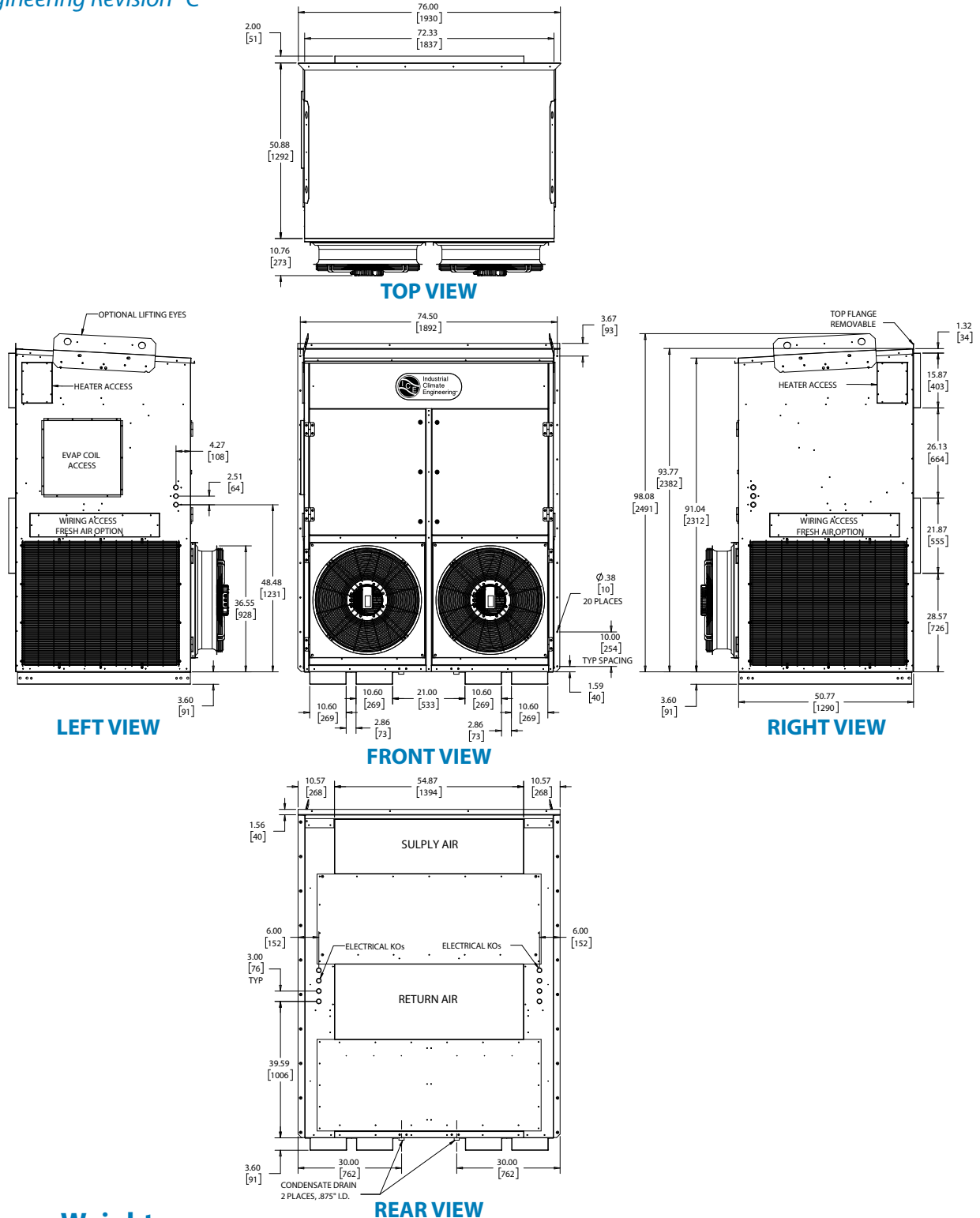

Weight

	LBS/KGS
CFH3240A	2523/1148



CFH3240A units require additional support if wall mounted. The mounting flanges alone are not adequate.

Filter Size

CFH3240A	INCHES	MILLIMETERS	PART NUMBER	FILTERS PER UNIT	MERV RATING
¹ Exterior Access Return Air Filter	25 x 16 x 2	635 x 406 x 51	80137	4	8 (STD)
² Interior Access Return Air Filter	24 x 18 x 2	610 x 457 x 51	81257	4	8 (STD)

¹Standard Configuration ²Optional (can not be combined)

Note: All overall outside dimensions are given with +/- .250" (6mm) tolerance.

Dimensional Data: CFH3240A - Top Supply/Center Return w/Economizer

Engineering Revision "C"

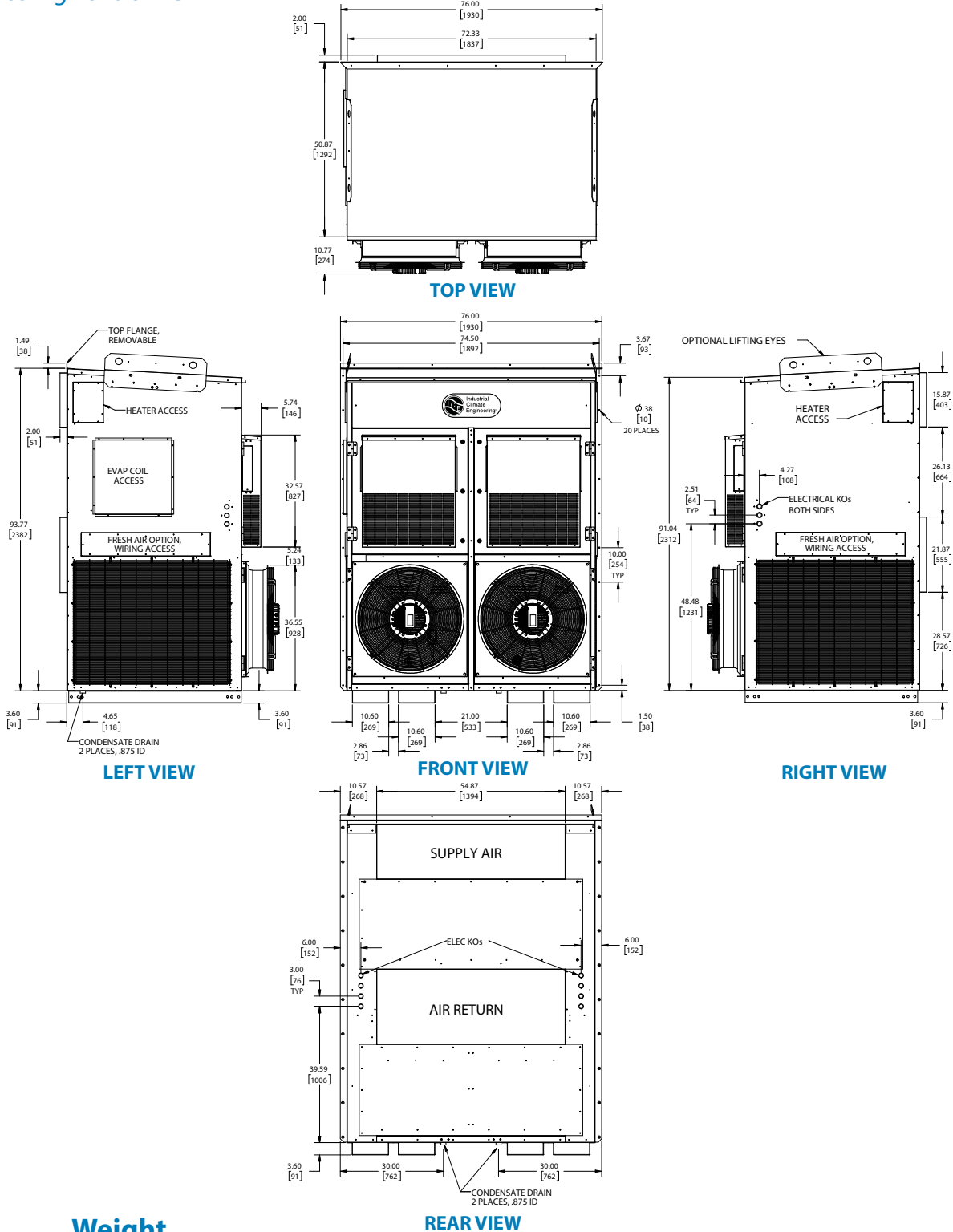

Weight

	LBS/KGS
CFH3240A	2663/1208



CFH3240A units require additional support if wall mounted. The mounting flanges alone are not adequate.

Filter Size

CFH3240A	INCHES	MILLIMETERS	PART NUMBER	FILTERS PER UNIT	MERV RATING
¹ Exterior Access Return Air Filter	25 x 16 x 2	635 x 406 x 51	80137	4	8 (STD)
² Interior Access Return Air Filter	24 x 18 x 2	610 x 457 x 51	81257	3	8 (STD)
Fresh Air Hood Pre-filters	26" x 12" x 1"	660 x 305 x 25	92526	2	N/A

¹Standard Configuration ²Optional (can not be combined) **Note:** All overall outside dimensions are given with +/- .250" (6mm) tolerance.

Dimensional Data: CFH3240A - Center Supply/Top Return

Engineering Revision "C"

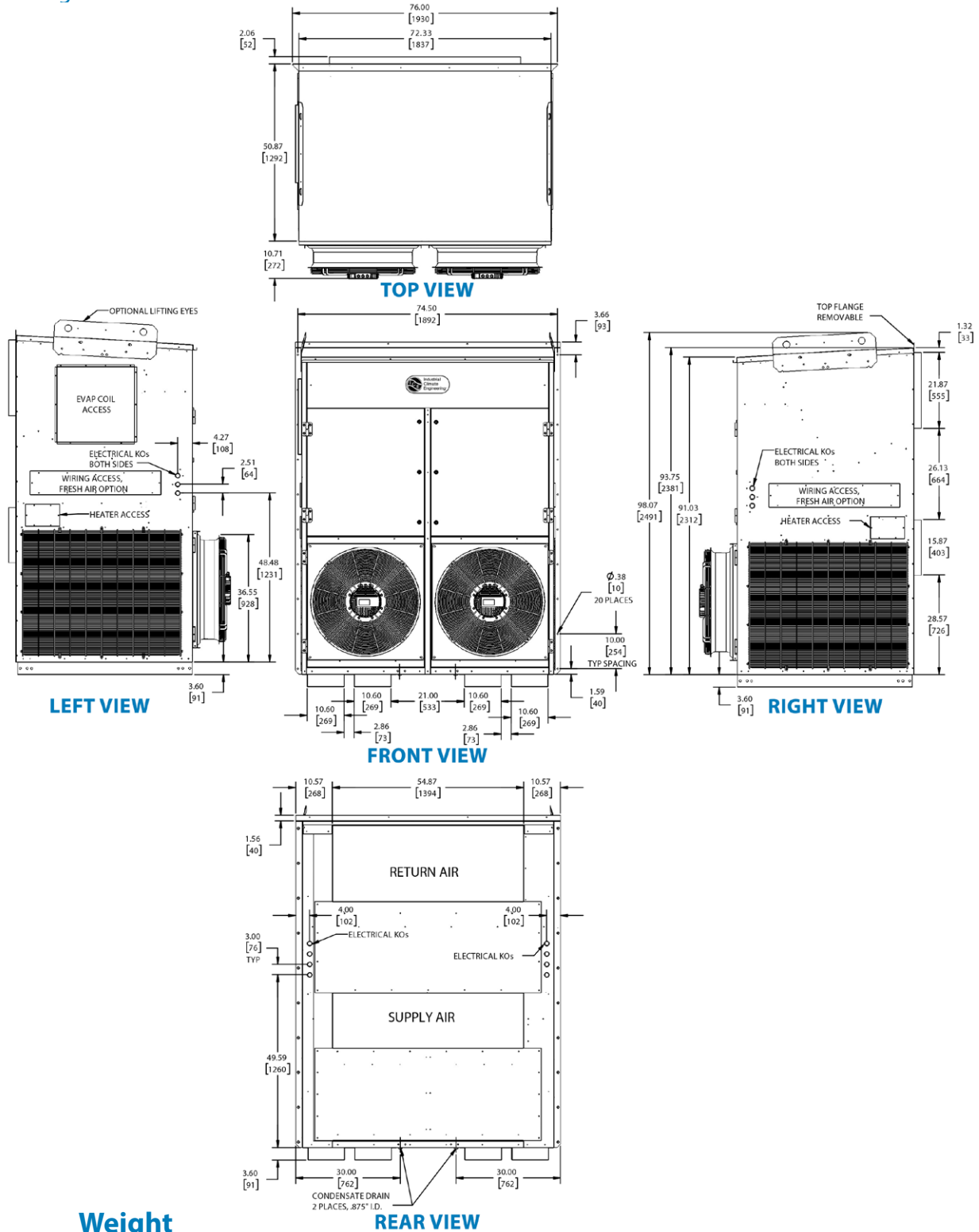

Weight

	LBS/KGS
CFH3240A	2523/1148



CFH3240A units require additional support if wall mounted. The mounting flanges alone are not adequate.

Filter Size

CFH3240A	INCHES	MILLIMETERS	PART NUMBER	FILTERS PER UNIT	MERV RATING
Interior Access Return Air Filter	24 x 18 x 2	610 x 457 x 51	81257	4	8 (STD)
Mist Eliminator Filter	15 5/8 x 24 5/8 x 1	397 x 625 x 25	92971	3	N/A

Note: All overall outside dimensions are given with +/- .250" (6mm) tolerance.

Dimensional Data: CFH3240A - Center Supply/Top Return w/Economizer

Engineering Revision "C"

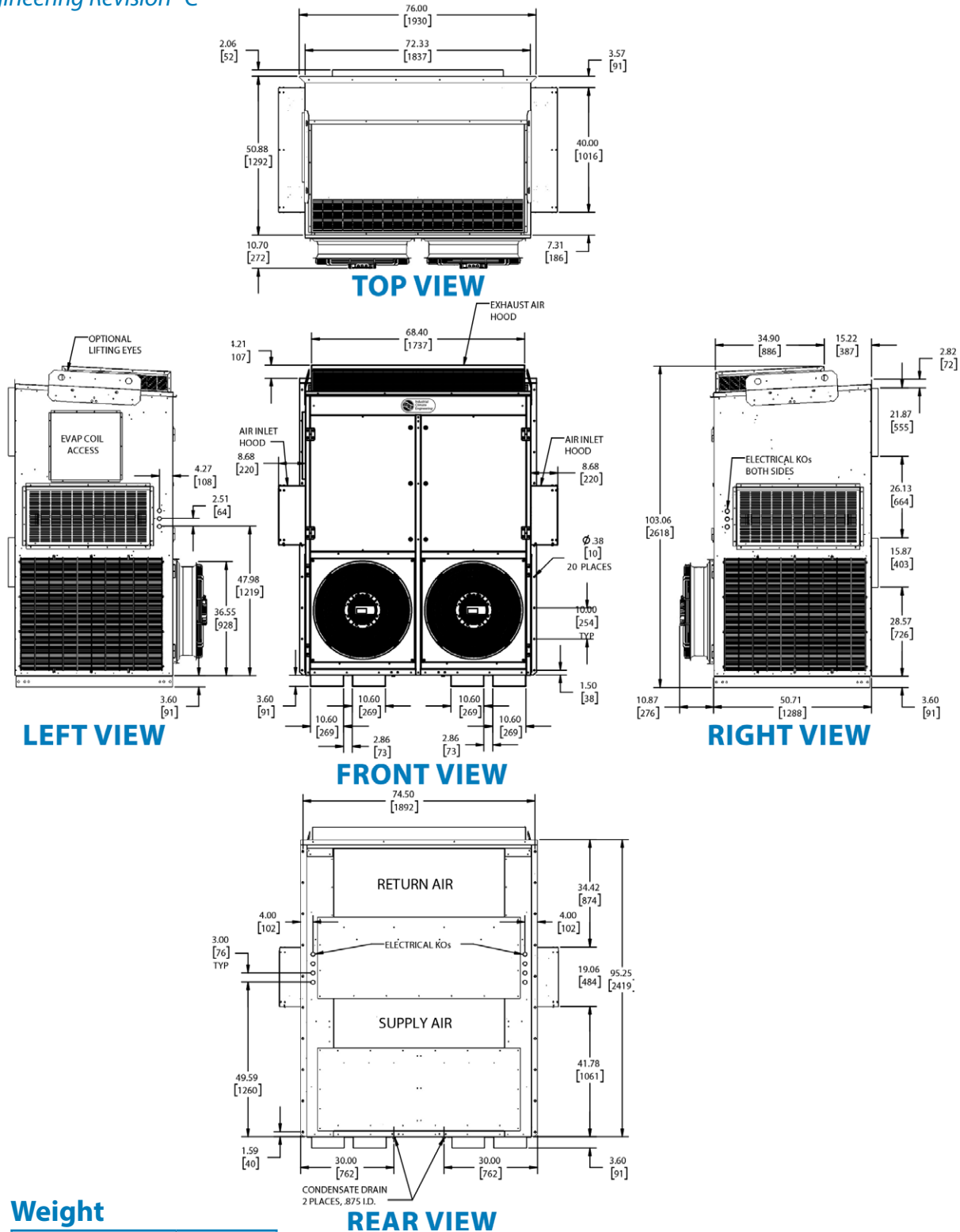

Weight

	LBS/KGS
CFH3240A	2345/1063



CFH3240A units require additional support if wall mounted. The mounting flanges alone are not adequate.

Filter Size

CFH3240A	INCHES	MILLIMETERS	PART NUMBER	FILTERS PER UNIT	MERV RATING
Interior Access Return Air Filter	24 x 18 x 2	610 x 457 x 51	81257	3	8 (STD)
Mist Eliminator Filter	15 5/8 x 24 5/8 x 1	397 x 625 x 25	92971	4	N/A
Fresh Air Hood Pre-filters	14 x 32 x 1	356 x 813 x 25	93187	2	N/A

Note: All overall outside dimensions are given with +/- .250" (6mm) tolerance.

Dimensional Data: CFH3300A/3360A - Top Supply/Center Return

Engineering Revision "B"

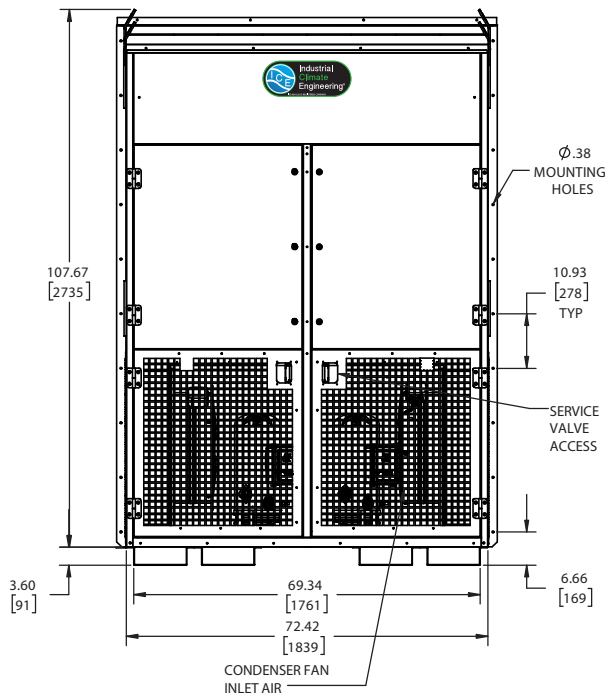

FRONT VIEW

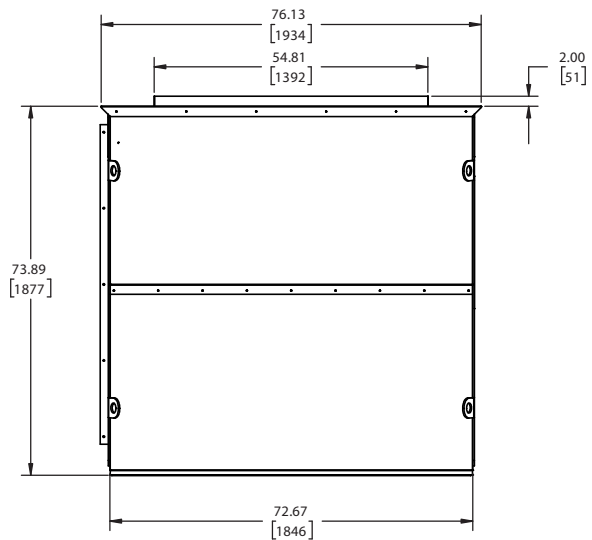

TOP VIEW

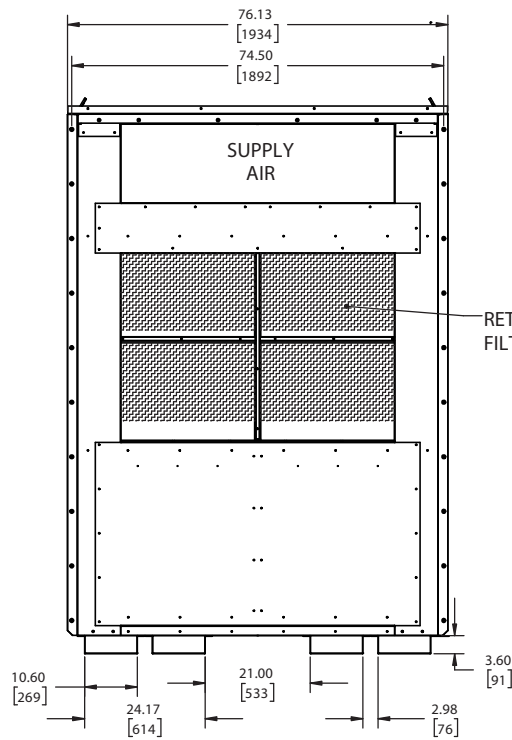

REAR VIEW

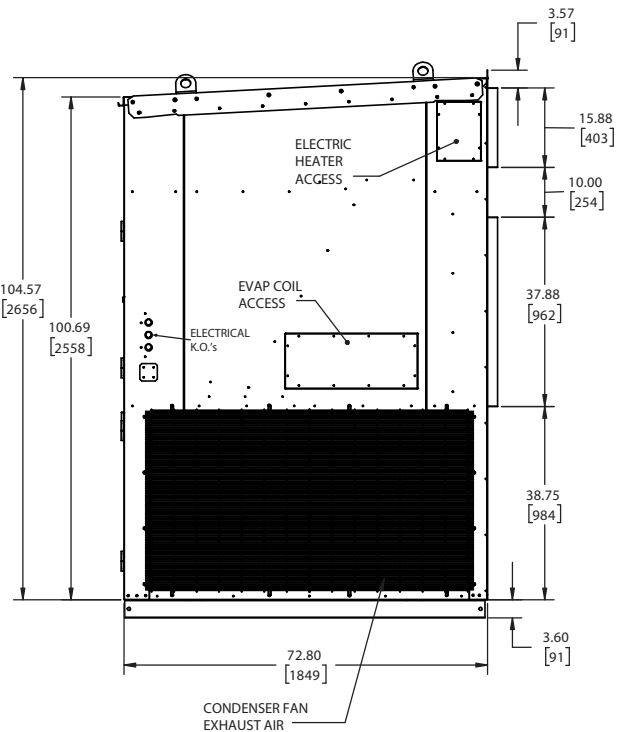

RIGHT VIEW

Weight

	LBS/KGS
CFH3300A/3360A	3055/1386



CFH3300A/3360A units require additional support if wall mounted. The mounting flanges alone are not adequate.

Filter Size

CFH3300A/3360A	INCHES	MILLIMETERS	PART NUMBER	FILTERS PER UNIT	MERV RATING
Interior Access Return Air Filter	30 x 20 x 2	762 x 508 x 51	92545	4	N/A
Fresh Air Filter (Economizer Only)	15 x 26 x 1	381 x 660 x 25	92982	2	8 (STD)

Note: All overall outside dimensions are given with +/- .250" (6mm) tolerance.

Dimensional Data: CFH3300A/3360A - Top Supply/Center Return w/Economizer

Engineering Revision "B"

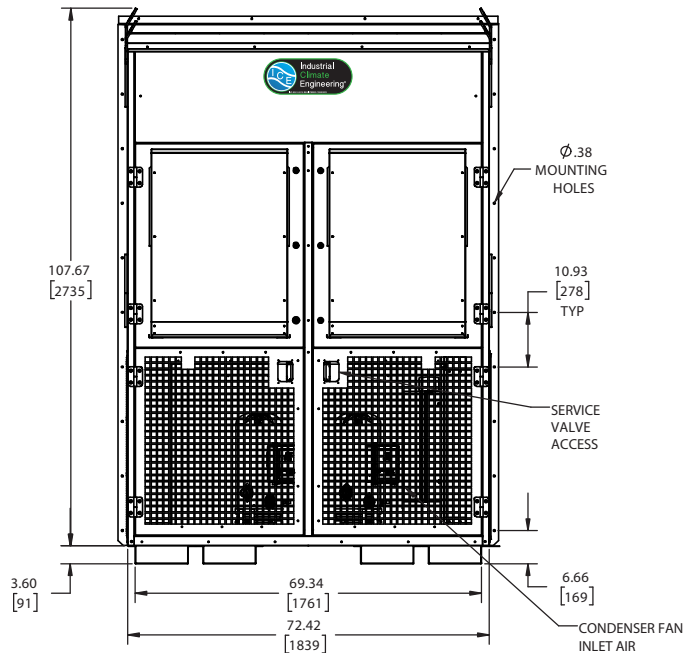

FRONT VIEW

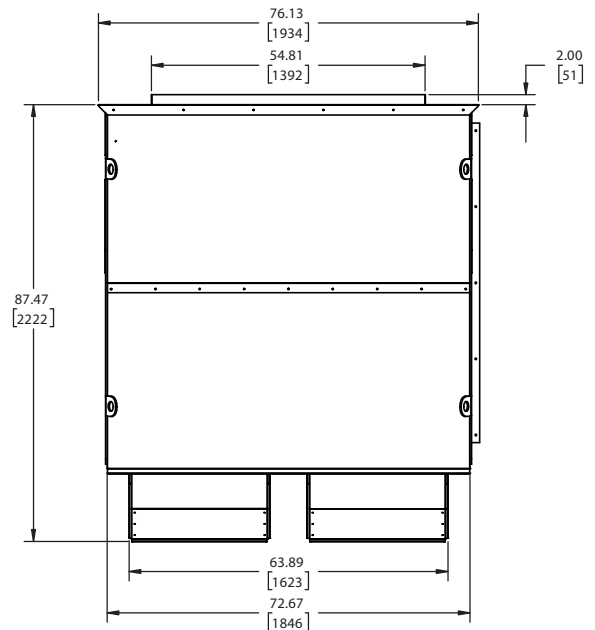

TOP VIEW

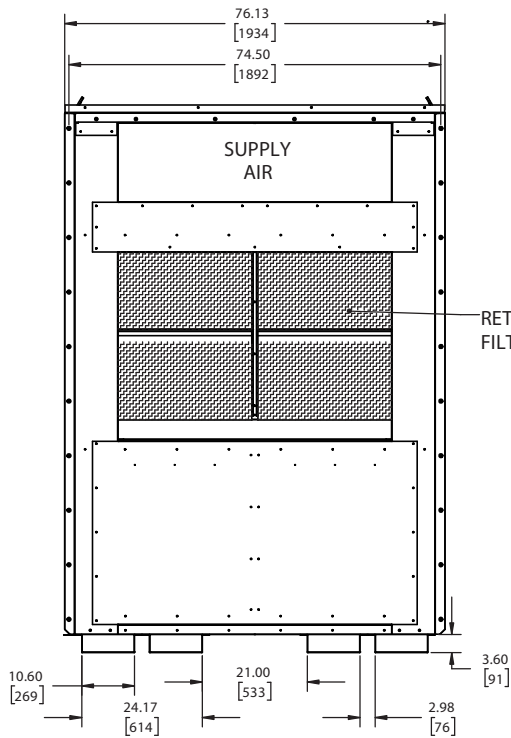

REAR VIEW

Weight

	LBS/KGS
CFH3300A/3360A	3055/1386

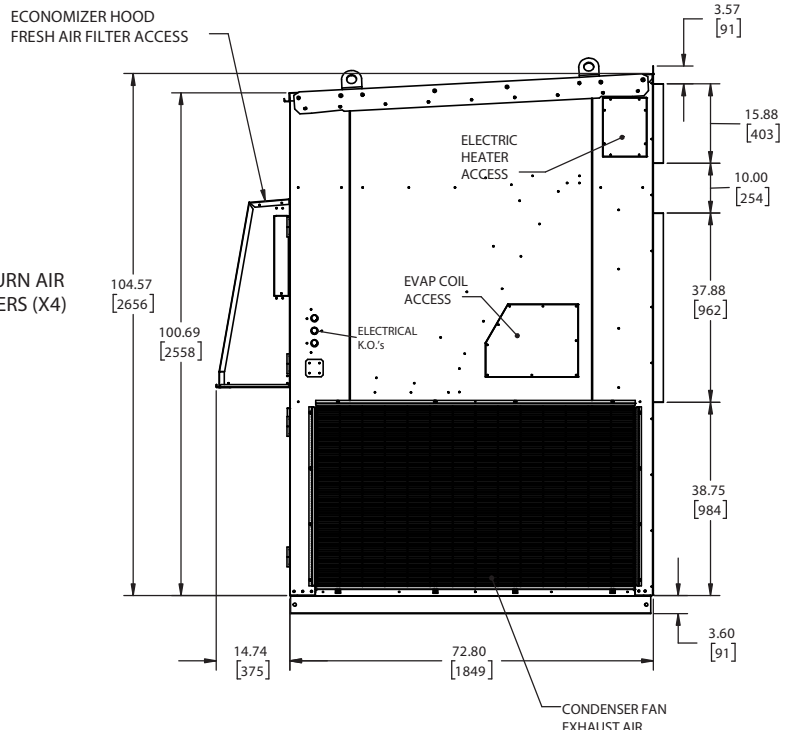

RIGHT VIEW



CFH3300A/3360A units require additional support if wall mounted. The mounting flanges alone are not adequate.

Filter Size

CFH3300A/3360A	INCHES	MILLIMETERS	PART NUMBER	FILTERS PER UNIT	MERV RATING
Interior Access Return Air Filter	30 x 20 x 2	762 x 508 x 51	92545	4	N/A
Fresh Air Filter (Economizer Only)	15 x 26 x 1	381 x 660 x 25	92982	2	8 (STD)

Note: All overall outside dimensions are given with +/- .250" (6mm) tolerance.

Dimensional Data: CFH3300A/3360A - Center Supply/Top Return

Engineering Revision "B"

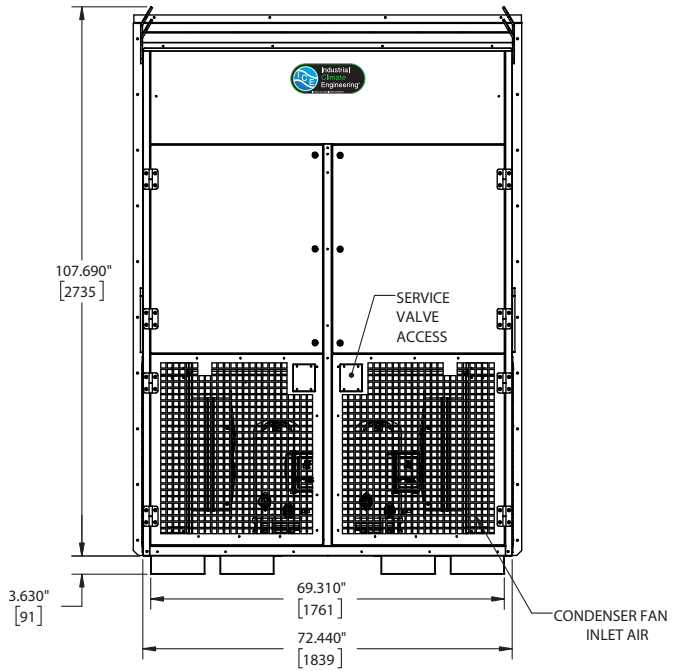

FRONT VIEW

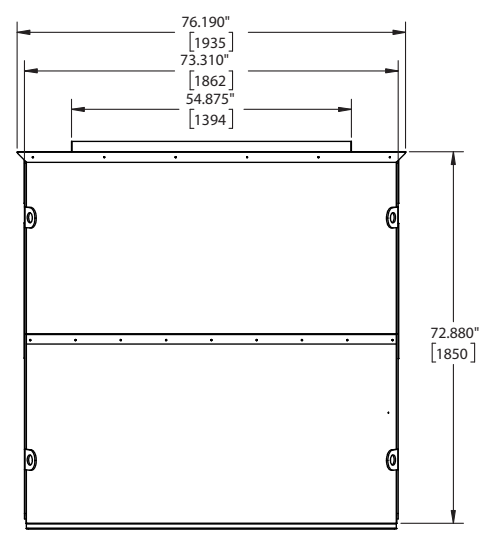

TOP VIEW

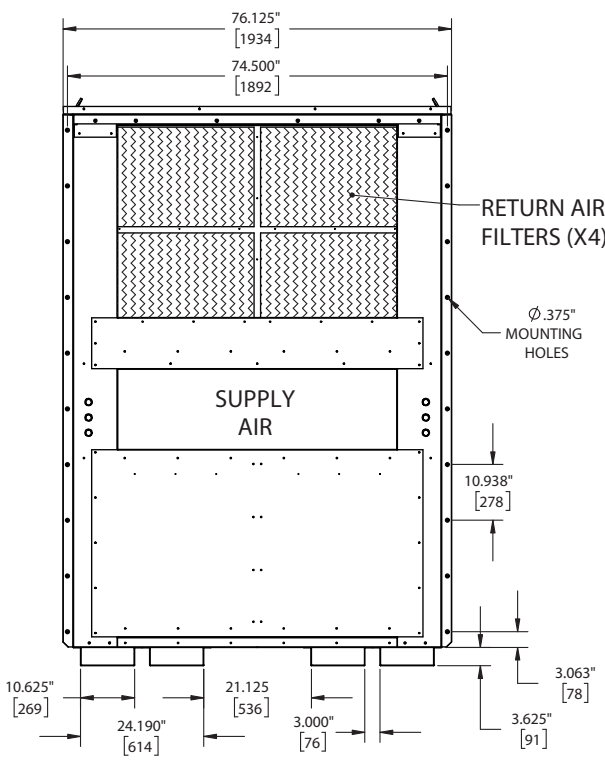

REAR VIEW

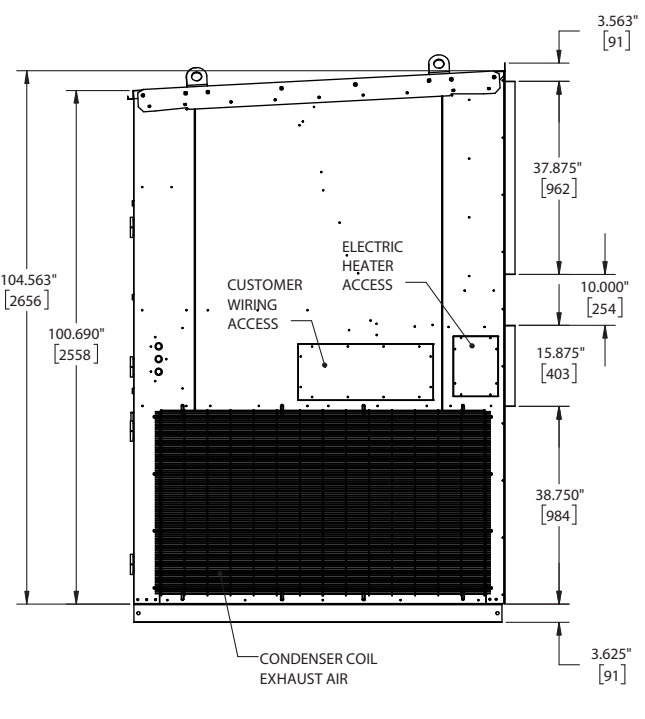

RIGHT VIEW

Weight

	LBS/KGS
CFH3300A/3360A	3055/1386

⚠ CFH3300A/3360A units require additional support if wall mounted. The mounting flanges alone are not adequate.

Filter Size

CFH3300A/3360A	INCHES	MILLIMETERS	PART NUMBER	FILTERS PER UNIT	MERV RATING
Interior Access Return Air Filter	30 x 20 x 2	762 x 508 x 51	92545	4	N/A
Mist Eliminator Filter	33 x 40 x 2	838 x 1,016 x 51	93269	2	N/A

Note: All overall outside dimensions are given with +/- .250" (6mm) tolerance.

Dimensional Data: CFH3300A/3360A - Center Supply/Top Return w/Economizer

Engineering Revision "B"

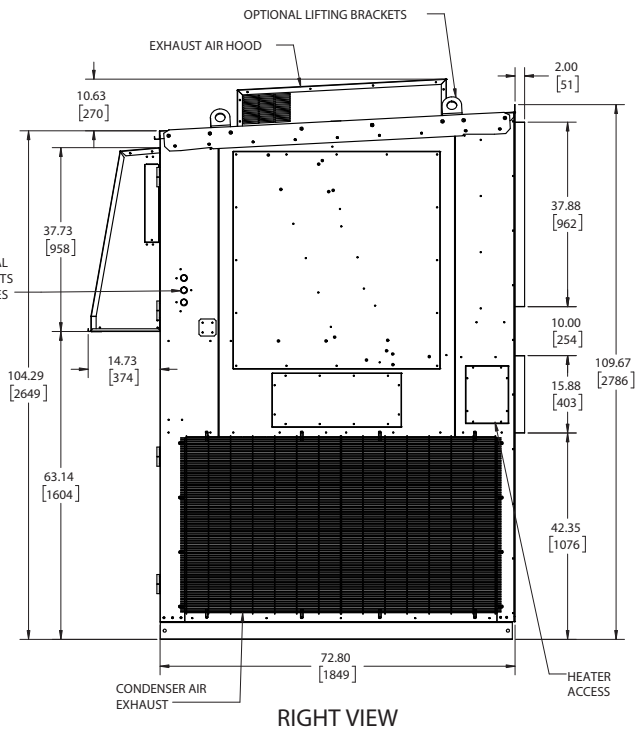
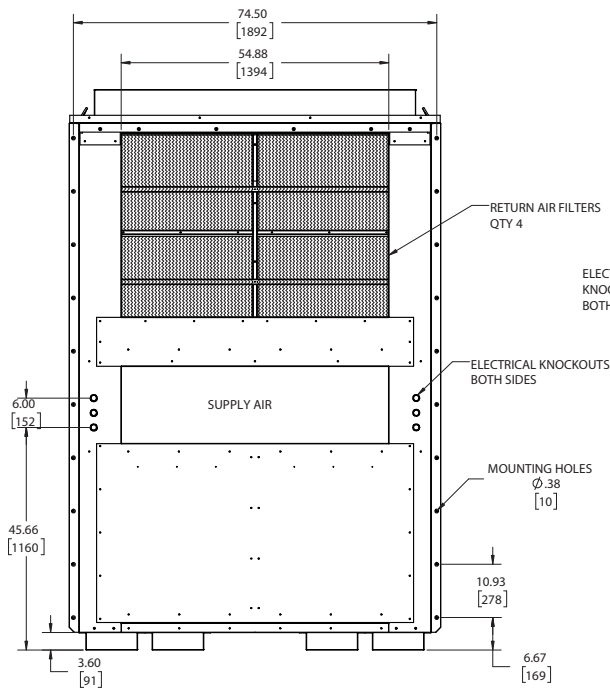
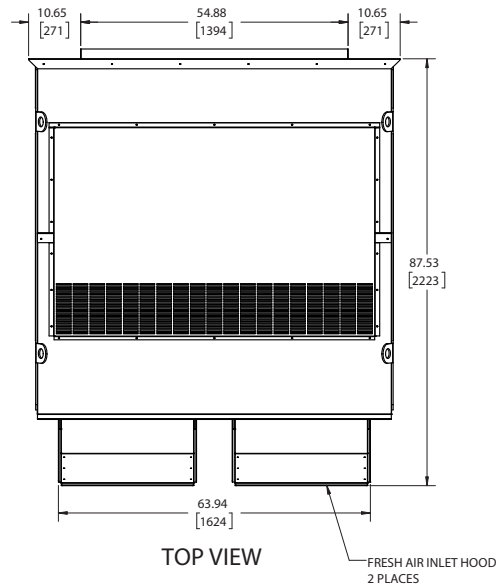
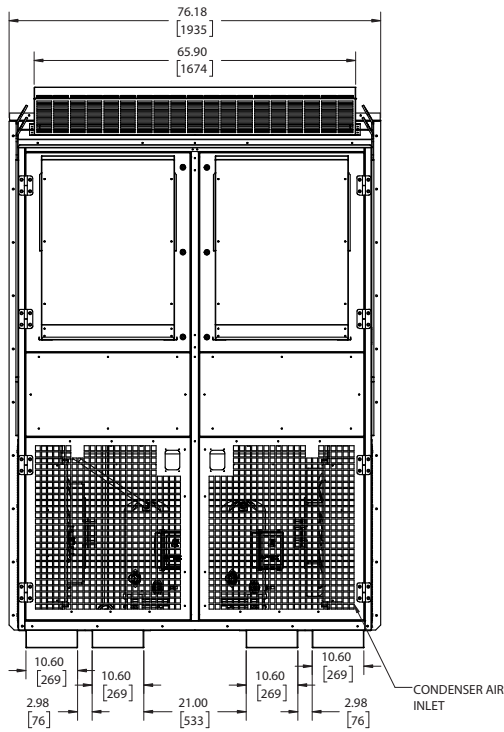

Weight

REAR VIEW

	LBS/KGS
CFH3300A/3360A	3150/1429



CFH3300A/3360A units require additional support if wall mounted. The mounting flanges alone are not adequate.

Filter Size

CFH3300A/3360A	INCHES	MILLIMETERS	PART NUMBER	FILTERS PER UNIT	MERV RATING
Interior Access Return Air Filter	20 x 30 x 2	508 x 762 x 51	92545	4	N/A
Mist Eliminator Filter	15 x 26 x 1	381 x 660 x 25	92982	2	N/A

Note: All overall outside dimensions are given with +/- .250" (6mm) tolerance.

CFH3240A Isometric View

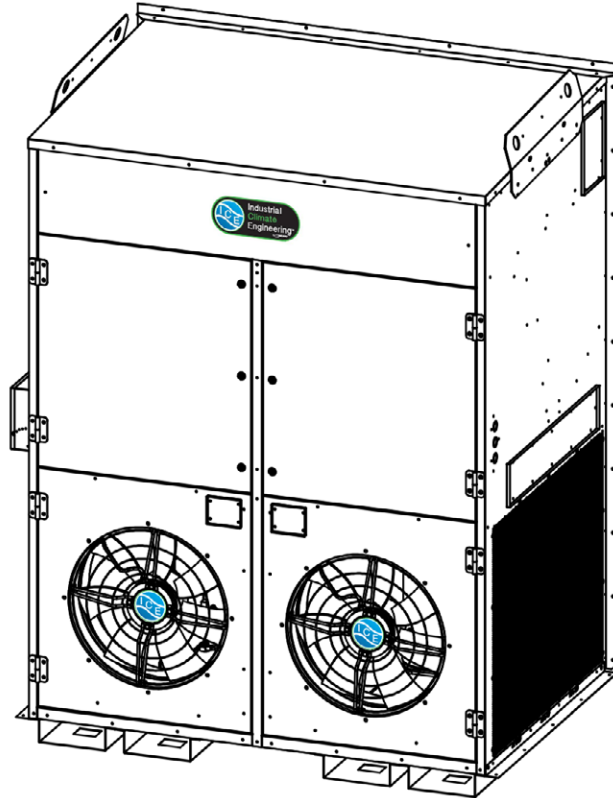

CFH3300A Isometric View

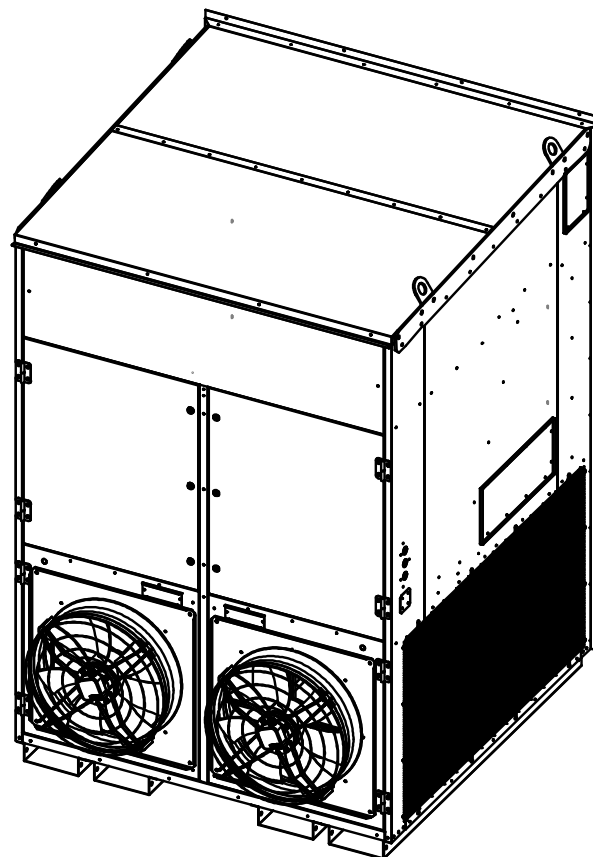

CFH3360A Isometric View

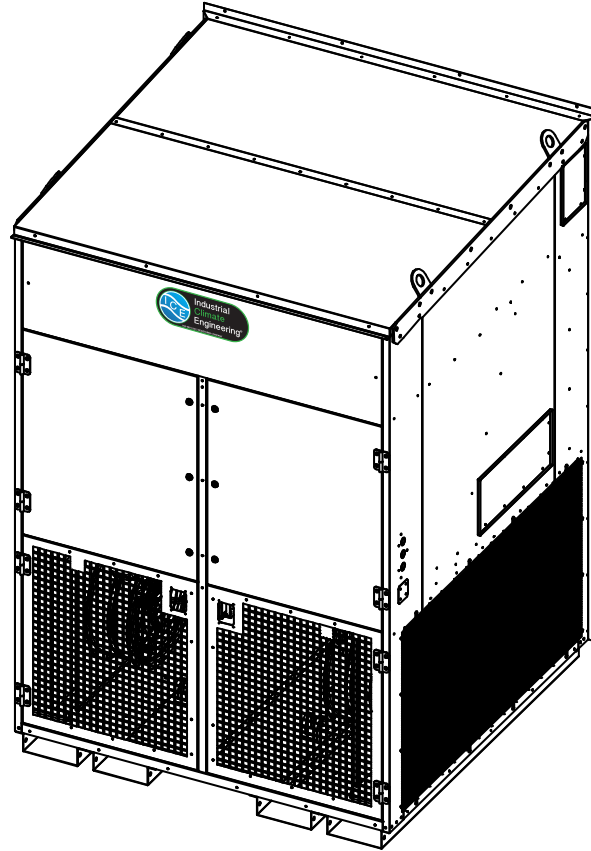

Please consult the Industrial Climate Engineering website at www.acice.com for the latest product literature. Detailed dimensional data is available upon request. A complete warranty statement can be found in each product's Installation/Operation Manual, on our website. As part of the ICE continuous improvement program, specifications are subject to change without notice.



P.O. Box 5104 • Cordele, GA 31010-5104
2002 Hoover St • Cordele, GA 31015
(229) 273-9558
Email: ice@airxcs.com • Internet: www.acice.com

