



Installation & Operation Manual Vertical Air Conditioners

CFA3240A/3300A/3360A



Manufactured By:

Industrial Climate Engineering™, An AirX Climate Solutions Brand

P.O. Box 5104 • Cordele, Georgia 31010
2002 Hoover St. • Cordele, Georgia 31015
(229) 273-9558 • Fax (229) 273-5154

E-mail: icesales@airxcs.com • Internet: www.acice.com

The most current version of this manual can be found at www.acice.com.

ICE CFA3240A-3300A-3360A I&O Manual 08/2024 Rev.19

How To Use This Manual

This manual is intended to be a guide to Industrial Climate Engineering's line of vertical air conditioners. It contains installation, troubleshooting, maintenance, warranty, and application information. The information contained in this manual is to be used by the installer as a guide only. This manual does not supersede or circumvent any applicable national or local codes.

If you are installing the air conditioner first read Chapter 1 and scan the entire manual before beginning the installation as described in Chapter 2. Chapter 1 contains general, descriptive information and provides an overview which can speed up the installation process and simplify troubleshooting.

If a malfunction occurs, follow this troubleshooting sequence:

1. Make sure you understand how the air conditioner works (Chapters 1 & 3).
2. Identify and correct installation errors (Chapter 2).
3. Refer to the troubleshooting information in Chapter 4.

If you are still unable to correct the problem, contact the Factory at 1-229-273-9558 for additional assistance.

Please read the following “Important Safety Precautions” before beginning any work.

Important Safety Precautions

1. USE CARE when LIFTING or TRANSPORTING equipment.
2. TRANSPORT the UNIT UPRIGHT. Laying it down on its side may cause oil to leave the compressor and breakage or damage to other components.
3. TURN ELECTRICAL POWER OFF AT THE breaker or fuse box BEFORE installing or working on the equipment. LINE VOLTAGES ARE HAZARDOUS or LETHAL.
4. OBSERVE and COMPLY with ALL applicable PLUMBING, ELECTRICAL, and BUILDING CODES and ordinances.
5. SERVICE may be performed ONLY by QUALIFIED and EXPERIENCED PERSONS.
 - * Wear safety goggles when servicing the refrigeration circuit
 - * Beware of hot surfaces on refrigerant circuit components
 - * Beware of sharp edges on sheet metal components
 - * Use care when recovering or adding refrigerant
6. Use COMMON SENSE - BE SAFETY-CONSCIOUS

This is the safety alert symbol . When you see this symbol on the air conditioning unit and in the instruction manuals be alert to the potential for personal injury. Understand the signal word DANGER, WARNING and CAUTION. These words are used to identify levels of the seriousness of the hazard.

 **DANGER** Failure to comply will result in death or severe personal injury and/or property damage.

 **WARNING** Failure to comply could result in death or severe personal injury and/or property damage.

 **CAUTION** Failure to comply could result in minor personal injury and/or property damage.

IMPORTANT Used to point out helpful info that will result in improved installation, reliability or operation.

SPECIFICATIONS SUBJECT TO CHANGE WITHOUT NOTICE.

© 08/2024 Industrial Climate Engineering™, An AirX Climate Solutions Brand

⚠ WARNING

- If the information in these instructions are not followed exactly, a fire may result causing property damage, personal injury or loss of life.
- Read all instructions carefully prior to beginning the installation. Do not begin installation if you do not understand any of the instructions.
- Improper installation, adjustment, alteration, service or maintenance can cause property damage, personal injury or loss of life.
- Installation and service must be performed by a qualified installer or service agency in accordance with these instructions and in compliance with all codes and requirements of authorities having jurisdiction.

INSTALLER: Affix the instructions on the inside of the building adjacent to the thermostat.

END USER: Retain these instructions for future reference.

Table of Contents

Chapter 1 Air Conditioner Description & Specifications

1.1	General Description	5
1.2	Model Identification	6
1.3	Serial Number Date Code	6
1.4	Air Flow, Weights and Filter Sizes.....	6
1.5	General Operation	7
1.6	Programmable Logic Controller	8
1.7	Optional Controls and Packages	9
1.8	Electrical Operation	10

Chapter 2 Installation

2.1	Equipment Inspection.....	13
2.2	Installation Requirements.....	13
2.3	Installation Materials	14
2.4	Porting and Duct Work	16
2.5	Top Flange Installation	16
2.6	Installing the Lifting Brackets.....	17
2.7	Mounting the Unit	17
2.8	Compressor Chocks Removal.....	18
2.9	Unit Support Recommendations	19
2.10	Electrical Connections	19

Chapter 3 Start-Up

3.1	Check-Out of Cooling Cycle	23
3.2	Check-Out of Heating Cycle.....	23

Table of Contents

Chapter 4 Troubleshooting

4.1 Overview	24
4.2 Failure Symptoms Guide.....	25
4.3 Compressor Troubleshooting	26
4.4 Control Board Diagnosis.....	26

Chapter 5 Maintenance

5.1 Scheduled Maintenance	27
---------------------------------	----

Chapter 6 Warranty

6.1 Limited Product Warranty.....	28
-----------------------------------	----

Chapter 7 Start-Up Check List

7.1 Start-Up Check List.....	29
------------------------------	----

Illustrations

Figure 1. Programmable Logic Controller	8
Figure 2a. Typical Electrical Schematic - CFA3240A	11
Figure 2b. Typical Electrical Schematic - CFA3300A & CFA3360A	12
Figure 3. Top Flange and Lifting Bracket Installation	17
Figure 4. Wall Mounting Detail.....	18
Figure 5. Compressor Chock Removal.....	18
Figure 6a. Unit Compression Support Examples	19
Figure 6b. Unit Tension Support Examples.....	19
Figure 7a. Humidistat Wiring to a Marvair Air Conditioner with Reheat.....	22
Figure 7b. CommStat 4 Connection Diagram	22

Tables

Table 1 Cooling Performance and Air Flow	7
Table 2 Filter Sizes/Part Numbers	7
Table 3 Shipping Weights & Dimensions.....	7
Table 4 Refrigerant Charge.....	7
Table 5 Minimum Clearances	14
Table 6 Voltage Limitations	14

Appendix A: PLC SetUp and Operation.....	33
---	-----------

Appendix B: PLC Sequence of Operation.....	42
---	-----------

Appendix C: PLC Modbus Variables	46
---	-----------

Appendix D: PLC Bacnet Analog Variables.....	49
---	-----------

Appendix E: PLC Bacnet Binary Variables.....	51
---	-----------

Appendix F: Fresh Air Damper Installation	52
--	-----------

Appendix G: CFA3240A Center Supply/Top Return w/Economizer Exhaust Hood Installation	54
---	-----------

Appendix H: Optional Condenser Filter Installation.....	55
--	-----------

Appendix I: DPC200 Differential Pressure Controller.....	56
---	-----------

Chapter 1 Description & Specifications

1.1 General Description

Industrial Climate Engineering's (ICE) "CFA" Environmental Control Units are a series of vertical wall-mounted air conditioning systems that provide heating, cooling, and ventilation for electronic equipment shelters, process control centers, E-Houses, and other applications with high internal heat gains. The series includes multiple sizes and nominal cooling capacities from 240,000 to 360,000 BTUH. Resistance heating elements are available in various wattages.

Industrial Climate Engineering models feature an exclusive electronic control board.

The control board consolidates several electrical components, improves the air conditioner's reliability and has LED's to indicate operating status and fault conditions to assist the service technician. A complete description of functions of the control board is in Section 1.6

Other standard components include:

- Hot gas by-pass valve provides for closer temperature control in mechanical cooling and protects against coil freeze-up during low load conditions.
- Thermal expansion valve to improve both efficiency and capacity over a wide range of ambient temperatures
- Phase monitor to prevent operation if the unit is not properly phased and high/low voltage

ICE CFA units are designed for easy installation and service. Major components are accessible for service beneath external panels.

All units have internal disconnects. Depending upon state and local code requirements, this feature may eliminate the need for an external breaker or disconnect.

1.2 Model Identification

The model identification number is found on the data sticker. Rating plate located on side panel.

Example	C	F	A	3	1	8	0	A	D	0	5	0	D	R	H	+	+	1	C	A	+	A	2	1	+	+	+	+	+	+
Position	1	2	3	4	5	6	7	8	9	10	11	12	13	14	15	16	17	18	19	20	21	22	23	24	25	26	27	28	29	30

1	Unit Designation/Family	C = Industrial Climate Engineering (ICE)
2	Energy Efficiency Ratio (EER)	F = EER <9
3	Refrigerant Type	A = R-410a
4	Compressor Type/Quantity	3 = Dual
5	Unit Capacity/Nominal Cooling (BTUH)	240 = 240,000
6		300 = 300,000
7		360 = 360,000
8	System Type	A = Air Conditioner
9	Power Supply (Volts-Hz-Phase)	A = 208/230-60-1 E = 380-50-3 (4 Wire) C = 208/230-60-3 M = 400-60-30 D = 460-60-3 Z = 575-60-3
10	Heat Designation	000 = No Heat 150 = 15KW 050 = 5KW 180 = 18KW 090 = 9KW
11	@ Rated Voltage	
12	KW = Kilowatt	
13	Ventilation Configuration	A = Solid Front Door C = Economizer D = Motorized Damper w/Pressure Relief E = Motorized Damper w/Pressure Relief & Independent Motorized Damper Control F = No Free Cooling, 100% Emergency Ventilation Only w/Independent Control
14	Dehumidification	R = Electric Reheat T = Electric Reheat w/Humidity Control + = None
15	Controls	F = PLC w/Summed Alarms H = PLC w/2-Stage Control 2 = PLC w/5-Stage Control + = None \$ = Special
16	Operating Condition	A = Evaporator Freeze Sensor (EFS) C = EFS w/Hot Gas Bypass M = Extreme Duty w/Hard Start & EFS N = Hard Start P = Hard Start w/Low Ambient & CCH Q = Hard Start w/Low Ambient & Fan Cycle Control (FCC) R = Crank Case Heater (CCH) T = Hard Start w/EFS U = Hard Start w/Hot Gas Bypass V = Hard Start w/Low Ambient & CCH & EFS W = Low Ambient w/CCH X = Hot Gas Bypass Y = Low Ambient w/CCH & FCC Z = Low Ambient w/CCH & EFS 1 = Low Ambient w/FCC 2 = Low Ambient w/FCC & EFS 3 = CCH w/Hot Gas Bypass + = None

Note: Not all options are available with all configurations. Contact your ICE sales representative for configuration details and feature compatibility.

17	Indoor Air Quality Features	A = UV Light D = Dry Bulb Sensor E = Dry Bulb Sensor w/Dirty Filter G = Dirty Filter Sensor K = Bi-Polar Ionization + = None
18	Air Flow	1 = Top Supply/Center Return (STD) 2 = Center Supply/Top Return
19	Compressor Location	C = Center
20	Filter Option	A = 2" Pleated (MERV 8, AC/HP-C) C = 2" Charcoal D = MERV 11 High Filtration Package E = MERV 13 High Filtration Package F = Filter Access Through Return Air Opening G = F + C H = F + D J = F + E K = F + W W = Aluminum Washable + = None
21	Corrosion Protection	A = Condenser Coil Only C = Evaporator Coil Only D = Both Coils Condenser & Evaporator E = All Coils Cond/Evap/Reheat F = Coat All K = Coastal Package + = None \$ = Special
22	Engineering	B2
23	Revision Level	C2
24	Cabinet Color	1 = Marvair Beige (STD) 2 = Gray (STD) 3 = Carlsbad Canyon (STD) 4 = White (STD) 5 = Stainless Steel Exterior 9 = Pebble Gray A = Stainless Steel - Unit \$ = Custom Color (Powder Coat)
25	Sound Attenuation	2 = Compressor Blanket + = None
26	Security Option	A = Lockable Access Plate/Tamper Proof B = Lockable Latch/Hinge + = None
27	Fastener/Drain Pan Option	A = Stainless Steel Fasteners C = Stainless Steel Drain Pan D = Stainless Steel Fasteners & Drain Pan + = None
28	Special Variation	+ = None \$ = Special Configuration Not Covered by Model Nomenclature
29	Unused	+ = None \$ = Special
30	Unused	+ = None \$ = Special

1.3 Serial Number Date Code

20 = 2020	01 = January	05 = May	09 = September
21 = 2021	02 = February	06 = June	10 = October
22 = 2022	03 = March	07 = July	11 = November
23 = 2023	04 = April	08 = August	12 = December

1.4 Weights and Filter Sizes

Electrical and performance specifications and dimensional drawings are in the Product Data Sheet.

Note: Follow local codes and standards when designing duct runs to deliver the required airflow. Minimize noise and excessive pressure drops caused by duct aspect ratio changes, bends, dampers and outlet grilles in duct runs.

Model Number	CFA3240	CFA3300	CFA3360
Cooling BTUH ¹	216,600	300,000	330,000
Rated Air Flow (CFM ²)	7,400	11,900	10,200
ESP ³ @ Rated Conditions	0.40	0.45	0.55

¹Cooling rated at 95°F (35°C) outdoor and 80°F DB/67° WB (26.5°C DB/19.5°C WB) return air
²CFM=Cubic Feet per Minute ³ESP=External Static Pressure
Ratings are with no outside air. Performance will be affected by altitude.
Ratings are at 230 volts for 208/230 volt units ("C" models), 460 volts for "D" models, 380 volts for "E" models, 575 volts for "Z" models. Derate performance by 17% for ACE (380v, 3ø, 50 Hz) models
Operation of units at a different voltage from that of the rating point will affect performance and air flow.

Table 1. Cooling Performance and Air Flow Ratings

MODEL	Description	Inches	Millimeters	Part #	# of Filters	MERV Rating
CFA3180/3240	Exterior Access Return Air Filter	25 x 16 x 2	635 x 406 x 51	80137	4	8 (STD)
CFA3180/3240	Interior Access Return Air Filter	24 x 18 x 2	610 x 457 x 51	81257	4	8 (STD)
CFA3240 w/Economizer	Fresh Air Hood Pre-filters	26 x 12 x 1	660 x 305 x 25	92526	2	N/A
CFA33240 Center Supply/ Top Return w/Economizer	Fresh Air Hood Pre-filters	16 x 32 x 1	406 x 813 x 25	93187	3	N/A
CFA3300/3360	Interior Access Return Air Filter	30 x 20 x 2	762 x 508 x 51	92545	4	8 (STD)
CFA3300/3360	Fresh Air Filter (Economizer Only)	15 x 26 x 1	381 x 660 x 25	92982	2	8 (STD)
CFA3300/3360 Center Supply/ Top Return	Mist Eliminator Filter	33 x 40 x 2	838 x 1,016 x 51	93269	2	N/A

Table 2. Filter Sizes/Part Numbers

MODEL	Unit Weight		Shipping Weight		Shipping Dimensions					
					Height		Width		Depth	
	LBS	KG	LBS	KG	Inches	MM	Inches	MM	Inches	MM
CFA3240	2,523	1,144	2,636	1,196	98	2,489	76	1,930	51	1,295
CFA3300	2,625	1,193	2,750	1,250	108	2,743	72	1,829	72	1,829
CFA3360	3,210	1,456	3,335	1,513	108	2,743	72	1,829	72	1,829

Table 3. Shipping Weights & Dimensions

Model	CFA3240	CFA3300	CFA3360
Refrigerant Charge (Oz)	264.5 ¹	432 ¹	416 ¹

¹Per circuit on dual compressor models

Table 4. Refrigerant Charge (R410A, Ounces)

1.5 General Operation

Hot Gas By-Pass

Standard on all models except the, Hot Gas By-Pass is normally used in specialty applications (i.e Magnetic Resonance Imaging (MRI) buildings) to prevent magnetic voltage disturbance caused by cycling. This technology is applied in this product to extend the operation envelope for the compressor to 20° F (-6.6°C). Combined with a condenser low ambient Fan Cycle feature, compressor operation can be extended to 0° F (-17.8°C). During Hot Gas operation mode, system performance will be reduced. If product operation is in mild outdoor ambient conditions, the installed shut-off ball valve may be closed, thus disabling the Hot Gas By-Pass feature.

Refrigerant Cycle (Cooling Mode)

The air conditioners use R-410A refrigerant in a conventional vapor-compression refrigeration cycle to transfer heat from air in an enclosed space to the outside. A motorized impeller assembly blows indoor air across the evaporator. Cold liquid refrigerant passing through the evaporator is boiled into gas by heat removed from the air. The warmed refrigerant gas enters the compressor where its temperature and pressure are increased. The hot refrigerant gas condenses to liquid as heat is transferred to outdoor air drawn across the condenser by the condenser fan. Liquid refrigerant is metered with a thermal expansion valve (TXV) into the evaporator to repeat the cycle.

Economizer

The factory installed economizer saves energy and reduces the run time on the compressor and condenser fan motor by using outside air – when suitable – to cool the shelter.

Note: The economizer option is currently available on the 1120,1150, 3180, 3240, 3300 and 3360.

On a signal from the wall mounted indoor thermostat that cooling is required, either mechanical cooling with the compressor or free cooling with the economizer is provided. A factory installed enthalpy controller determines whether the outside air is sufficiently cool and dry to be used for cooling. If suitable, the compressor is locked out and the economizer damper opens to bring in outside air through fresh air hoods located on each side of the air conditioner. The outside air is filtered with filters in each of the outside air hoods. Integral pressure relief allows the interior air to exit the shelter, permitting outside air to enter the shelter. The temperature at which the economizer opens is adjustable from 63°F (17°C) at 50% Relative Humidity to 73°F (23°C) at 50% Relative Humidity.

After the enthalpy control has activated and outside air is being brought into the building, the mixed air sensor measures the temperature of the air entering the indoor blower and then modulates the economizer damper to mix the right proportion of cool outside air with warm indoor air to maintain 50°-63°F (10° - 17°C) air being delivered to the building. This prevents shocking the electronic components with cold outside air.

The compressor is not permitted to operate when the economizer is functioning.

If the outside air becomes too hot or humid, the economizer damper closes completely, or to a field selectable minimum open position, and mechanical cooling is activated.

Fresh air hoods with prefilters are field installed on each side of the air conditioner.

CFA(Dual Compressor) Units: The CFA is factory wired for maximum cooling utilizing both compressors. If 2 stage compressor operation is desired, the factory installed jumper between terminals 1 and 2 of the low voltage terminal strip must be removed. The 1st stage cooling input is terminal 1 of the low voltage terminal strip and the 2nd stage cooling input is terminal 2 of the low voltage terminal strip. The thermostat must be programmed for 2 stage cooling operation when 2 stage compressor operation is desired.

Heating Mode

A wall-mounted thermostat controls the heating cycle of models which incorporate resistance heating elements. On a call for heat, the thermostat closes the heat relay to energize the indoor fan and the resistance elements.

1.6 Programmable Logic Controller

MGA3090A-3180A models include a factory installed PLC to control the operation of the HVAC system. The built-in PLC display screen shows operational status and provide assistance with diagnosis if troubleshooting is ever required. Various control functions are field selectable and programmable. The PLC is also capable of communicating to other PLCs to allow run time leveling and does not require additional equipment to be installed. The PLC provides improved reliability because of the reduction of components. The components utilized are more durable and the control box wiring has been simplified. Pertinent statistical data about the life of the refrigeration system can be accessed through the PLC.

The PLC is factory installed and tested, requires no adjustments or changes when the air conditioning system is installed.



Figure 1.
Programmable Logic Controller

Location

Remove the HVAC unit front access panel and open the panel door to the control cabinet. The PLC is located on the left side the low voltage section of the control box.

PLC Inputs & Outputs

Relay outputs can be located on the top of the PLC. The PLC has 1(Qty) Form C relay that is used as a common alarm output. All other outputs are used for Air conditioning operation. Along the bottom of the PLC, there are 7 banks of terminals, which represents 4 analog outputs, 8 digital inputs and 8 Analog inputs. The PLC also comes with communication interface for MODBUS RS485, BACnet MSTP, BACnet IP and MODBUS IP. A built in power supply is also integrated into the PLC for powering peripheral sensors.

See Appendix A for more PLC related information

1.7 Optional Controls & Packages

Protective Coating Packages

Coated Coils: Either the condenser or evaporator coil can be coated. For harsh conditions, e.g., power plants, paper mills or sites where the unit will be exposed to salt water, the coils should be coated. **Note:** Cooling capacity may be reduced by up to 5% on units with coated coils.

Coastal Environmental Package: This package includes:

- Corrosion resistant fasteners,
- Sealed or partially sealed condenser fan motor,
- Coating applied to all exposed internal copper and metal in the in the condenser section, and
- A protective coating on the condenser coil.

All Coat Package: Includes the same features as the Coastal Environmental Package and adds a coating on the evaporator coil and on all exterior and interior components and sheet metal. (**Note:** the insulated internal sheet metal and the internal control box are not coated).

Dirty Filter Indicator

A diaphragm type of indicator measures the air pressure on either side of the filter and when the pressure drops below the set point, a red LED is illuminated. The set point is adjustable.

Cabinet Color

ICE air conditioners are available in six different cabinet colors. The standard colors are Marvair® beige, white, gray and Carlsbad Canyon (brown). The standard cabinet's sides, top and front panels are constructed of 20 gauge painted steel. Contact your ICE representative for color chips. Custom colors are also available; contact ICE for details.

Two stainless steel cabinet constructions are available:

Stainless Steel Exterior (Option “5”): This option replaces all standard exterior painted surfaces with stainless steel. This option also replaces the standard unpainted compressor base of the unit and exterior cabinet screws with stainless steel. No other standard construction surfaces are stainless steel in this option, unless listed in this description. Back panel is not stainless steel with this option. This option is designed to give a more economical alternative to full stainless steel, and still offer an enhanced level of protection. For further corrosion protection, please see our “A” offering at full stainless on all metal components.

Stainless Steel Unit (Option “A”): This option replaces all interior and exterior steel sheet metal parts with stainless steel. All galvanized and painted steel surfaces found in the standard unit are stainless steel with this option. All cabinet screws are stainless steel. No other standard construction surfaces are stainless steel, unless listed in this description. This option is designed to give our most robust protection against steel corrosion.

Fresh Air Damper

Allows introduction of outside air into the building to provide positive pressurization. Field installed on either the left or right hand side of the unit. See Appendix A for installation instructions.

Model Number	Fresh Air Damper Part #	Fresh Air Damper Filter Part #	Fresh Air Damper Filter Size In (mm)
CFA3240	K/04757-xxx	92127	9¼" x 37" x ¾" (235 x 940 x 10)
CFA3300/3360	K/10169-xxx	92526	12" x 26" x 1" (305 x 660 x 25)

xxx designates the color. 200 = Grey (standard). 100 = Beige. 500 = Stainless Steel

Crankcase Heater

Crankcase Heater Recommended for use for units installed in cold climates.

Dual Compressors With Lead/Lag Operation

Freeze Sensor On Indoor Coil

Prevents frost on the indoor coil caused by a loss of air flow or restrictive duct work.

Filter Access From Return Air Grille

Factory or field installed filter bracket allows changing and access to the filters from the return air grille. See model ID, special option code "I".

Center Supply/Top Return Configuration

Location of Supply and Return Air Openings are reversed.

1.8 Electrical Operation

The compressor and condenser fan are energized with a contactor controlled by a 24 VAC pilot signal. Some compressors incorporate an internal PTC crankcase heater that functions as long as primary power is available. The heater drives liquid refrigerant from the crankcase and prevents loss of lubrication caused by oil dilution. Power must be applied to the unit for 24 hours before starting the compressor.

The condenser (outside fan) motor is energized by the same contactor.

The indoor evaporator fan motor is controlled by the fan purge on the electronic control board.

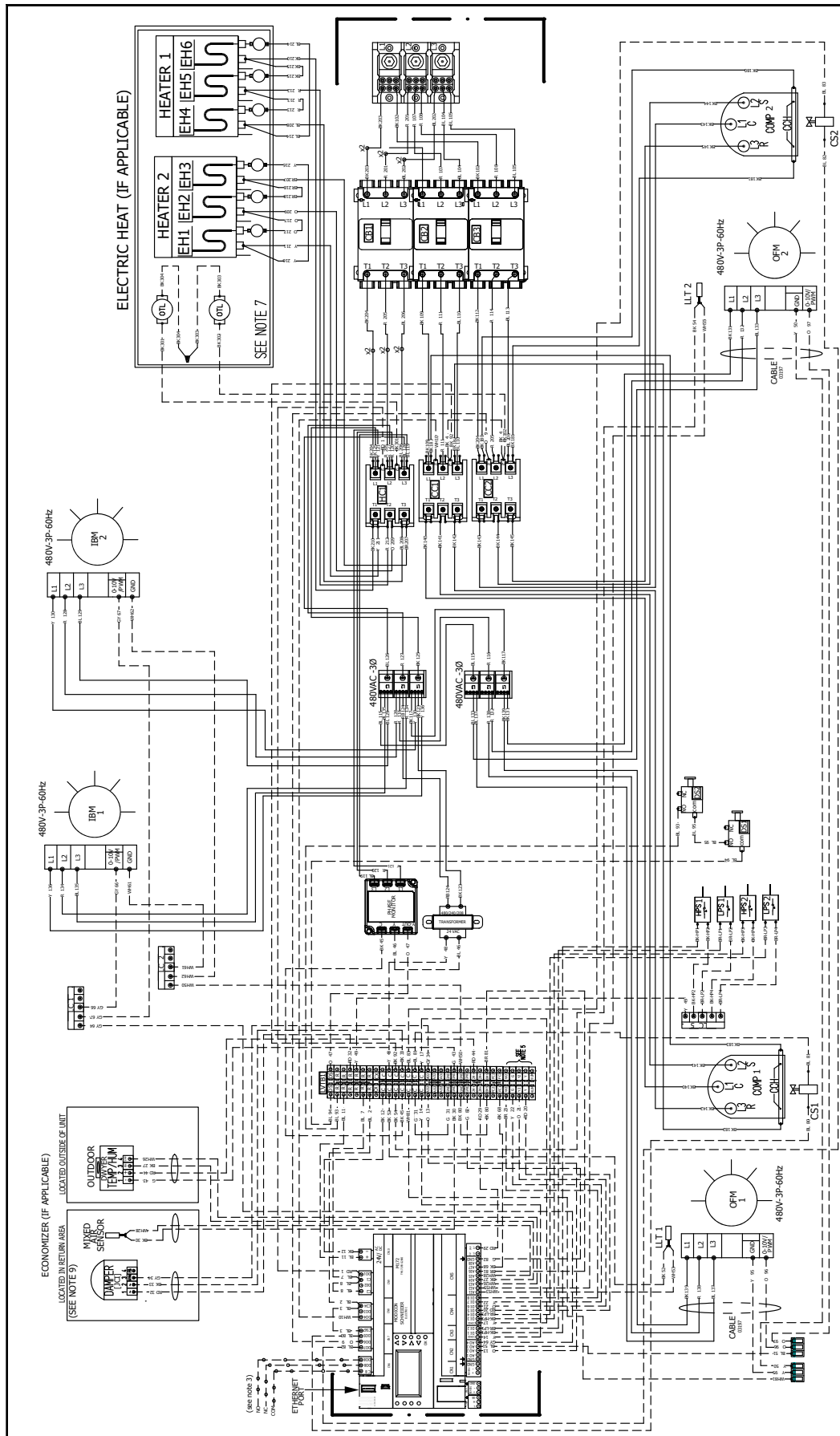

SCHMATIC DIAGRAM CAUTION: ELECTRICAL SHOCK HAZARD DISCONNECT POWER BEFORE SERVICING		TITLE: 20 TON 480-30-60 PLC UNIT W/ ECONOMIZER AND HEAT (IF APP) K/50016 K/50117 K/50118 REVISION RECORD <table border="1"> <tr><th>REV</th><th>DATE</th><th>BY</th><th>DESCRIPTION</th></tr> <tr><td>2319</td><td>3/27/2021</td><td>SYR</td><td></td></tr> <tr><td></td><td></td><td>SYR</td><td></td></tr> </table>	REV	DATE	BY	DESCRIPTION	2319	3/27/2021	SYR				SYR	
REV	DATE	BY	DESCRIPTION											
2319	3/27/2021	SYR												
		SYR												
ELECTRICAL LEGEND: OPM - COMPRESSOR CCH - CRANKCASE HEATER DA - DAMPER ACTUATOR DIA - DAMPER EHS - ELECTRIC HEAT ELEMENT FOC - FAN CYCLE CONTROL FCR - FAN CONTROL RELAY		VOLTAGE LEGEND: LINE VOLTAGE FACTORY LOW VOLTAGE FIELD ALT. VOLTAGE (FIELD SPEC.) COLOR CODE BK - BLACK BL - BLUE BR - BROWN G - GREEN O - ORANGE R - RED Y - YELLOW WH - WHITE WITH RED STRIPE												
GENERAL NOTES: 1. 480 VOLT 60 Hz, 3P POWER SUPPLY. SEE DATA PLATE FOR AMPLACITY & FUSE SIZE. OPTIONAL CKT BRK SHOWN. 2. CONTROL TRANSFORMER IS FACTORY WIRED FOR 480 VOLT OPERATION. 3. SEE DATA PLATE FOR WIRING INSTRUCTIONS. 4. THE SYSTEMS FACTORY WIRING FOR STAGED CAPACITY. ADD LABELS BETWEEN TERMINAL Y AND Y2 FOR FULL CAPACITY OPERATION. 5. SYSTEMS FACTORY WIRING. THIS APPLICABLE IS NOT APPLICABLE TO OLD CUSTOMER CAN INTERLOCK. SAFETY HERE DRY CONTACTS ONLY. 6. DAMPER INSTALLED AT FACTORY. 7. THESE COMPONENTS ARE ASSOCIATED TO THE HEATER CIRCUIT. SINGLE STAGE HEAT ONLY. DISREGARD IF THERE IS NO HEATER. 8. CKT1 IS THE BREAKER FOR CONTROLS, MOTORS AND HEATER. CKT2 AND CKT3 IS FOR COMPRESSOR 1 AND COMPRESSOR 2 RESPECTIVELY. 9. ONLY AVAILABLE IN UNITS WITH ECONOMIZER. DISREGARD IF CHARACTER F CHARACTER IS OF MODEL NUMBER IS NOT A "F".		REVISION RECORD: DATE: 6/14/2022 BY: J. SAMUELS DESCRIPTION: CFA000-240AD-P-C2-R0												

Figure 2a. Typical Electrical Schematic - CFA3240A

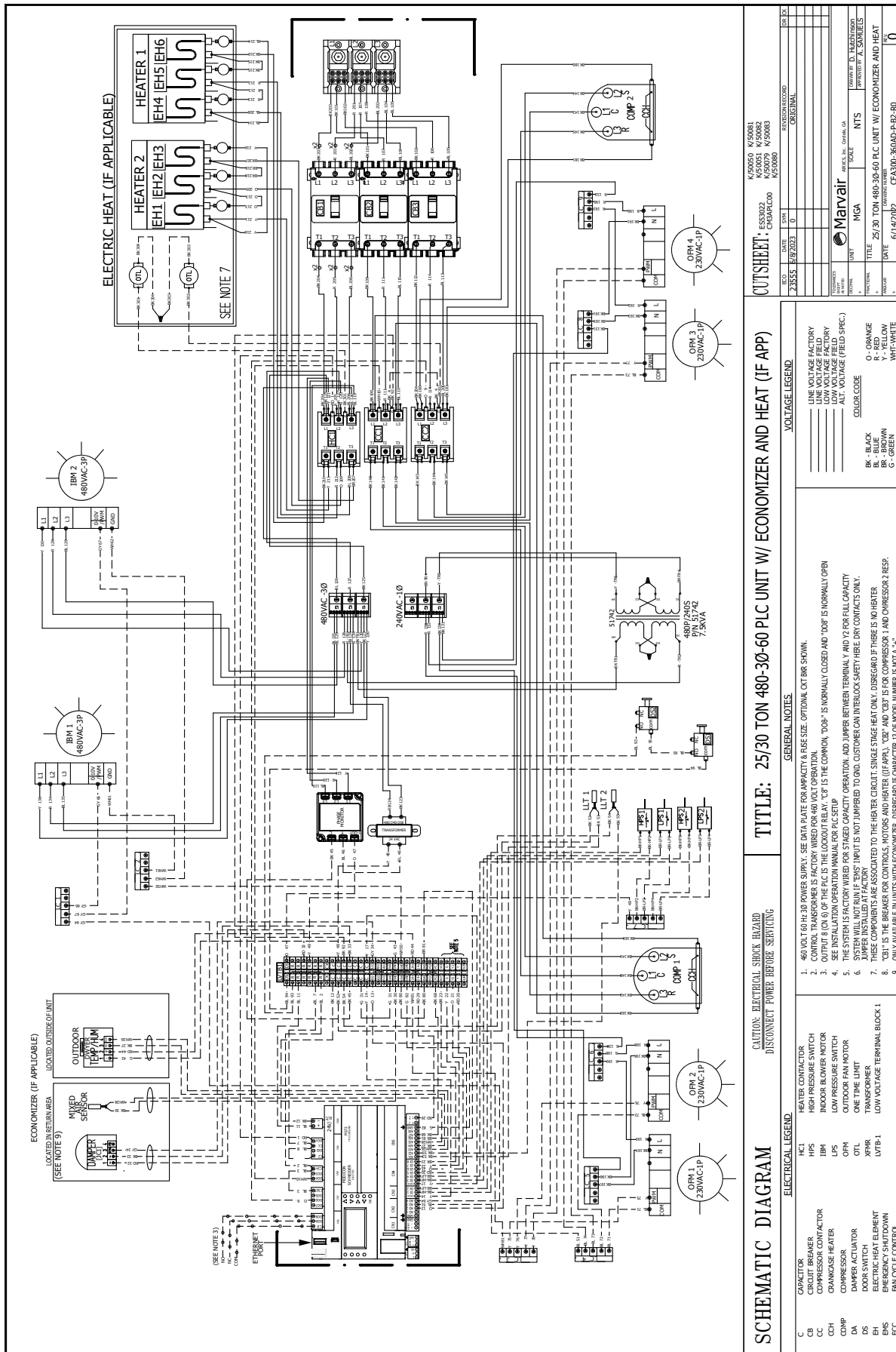

Figure 2b. Typical Electrical Schematic - CFA3300A & CFA3360A

SCHEMATIC DIAGRAM		TITLE: 25/30 TON 480-30-60 PLC UNIT W/ ECONOMIZER AND HEAT (IF APP)																																													
CAUTION: ELECTRICAL SHOCK HAZARD DISCONNECT POWER BEFORE SERVICING		GENERAL NOTES																																													
<p>ELECTRICAL LEGEND:</p> <table border="0"> <tr><td>C</td><td>CAPACITOR</td></tr> <tr><td>CB</td><td>CIRCUIT BREAKER</td></tr> <tr><td>CC</td><td>COMPRESSOR CONTACTOR</td></tr> <tr><td>CC</td><td>CRANKCASE HEATER</td></tr> <tr><td>CCH</td><td>COMPRESSOR</td></tr> <tr><td>DA</td><td>DAMPER ACTUATOR</td></tr> <tr><td>DS</td><td>DAMPER SWITCH</td></tr> <tr><td>EH</td><td>ELECTRIC HEAT ELEMENT</td></tr> <tr><td>ESC</td><td>ELECTRIC SHOCK DOWN</td></tr> <tr><td>FC</td><td>FAN</td></tr> <tr><td>FCC</td><td>FAN CYCLE CONTROL</td></tr> </table>	C	CAPACITOR	CB	CIRCUIT BREAKER	CC	COMPRESSOR CONTACTOR	CC	CRANKCASE HEATER	CCH	COMPRESSOR	DA	DAMPER ACTUATOR	DS	DAMPER SWITCH	EH	ELECTRIC HEAT ELEMENT	ESC	ELECTRIC SHOCK DOWN	FC	FAN	FCC	FAN CYCLE CONTROL	<p>VOLTAGE LEGEND:</p> <table border="0"> <tr><td>---</td><td>LINE VOLTAGE FACTORY</td></tr> <tr><td>---</td><td>LINE VOLTAGE FIELD</td></tr> <tr><td>---</td><td>LOW VOLTAGE FACTORY</td></tr> <tr><td>---</td><td>LOW VOLTAGE FIELD</td></tr> <tr><td>---</td><td>ALT. VOLTAGE (FIELD SPEC.)</td></tr> </table> <p>COLOR CODE:</p> <table border="0"> <tr><td>O</td><td>ORANGE</td></tr> <tr><td>R</td><td>RED</td></tr> <tr><td>W</td><td>WHITE</td></tr> <tr><td>BK</td><td>BLACK</td></tr> <tr><td>BL</td><td>BLUE</td></tr> <tr><td>GR</td><td>GREEN</td></tr> <tr><td>Y</td><td>YELLOW</td></tr> </table>	---	LINE VOLTAGE FACTORY	---	LINE VOLTAGE FIELD	---	LOW VOLTAGE FACTORY	---	LOW VOLTAGE FIELD	---	ALT. VOLTAGE (FIELD SPEC.)	O	ORANGE	R	RED	W	WHITE	BK	BLACK	BL	BLUE	GR	GREEN	Y	YELLOW
C	CAPACITOR																																														
CB	CIRCUIT BREAKER																																														
CC	COMPRESSOR CONTACTOR																																														
CC	CRANKCASE HEATER																																														
CCH	COMPRESSOR																																														
DA	DAMPER ACTUATOR																																														
DS	DAMPER SWITCH																																														
EH	ELECTRIC HEAT ELEMENT																																														
ESC	ELECTRIC SHOCK DOWN																																														
FC	FAN																																														
FCC	FAN CYCLE CONTROL																																														
---	LINE VOLTAGE FACTORY																																														
---	LINE VOLTAGE FIELD																																														
---	LOW VOLTAGE FACTORY																																														
---	LOW VOLTAGE FIELD																																														
---	ALT. VOLTAGE (FIELD SPEC.)																																														
O	ORANGE																																														
R	RED																																														
W	WHITE																																														
BK	BLACK																																														
BL	BLUE																																														
GR	GREEN																																														
Y	YELLOW																																														
<p>1. 480 VOLT 60 Hz 3Ø POWER SUPPLY. SEE DATA PLATE FOR AMPACITY & RISE SIZE. OPTIONAL OTR BKR SHOWN.</p> <p>2. CONTROL TRANSFORMER IS FACTORY WIRED FOR 480 VOLT OPERATION.</p> <p>3. THE SYSTEM IS FACTORY WIRED FOR STAGED CAPACITY OPERATION. ADD JUMPER BETWEEN TERMINAL Y AND Y2 FOR FULL CAPACITY.</p> <p>4. THE SYSTEM IS FACTORY WIRED FOR STAGED CAPACITY OPERATION. ADD JUMPER BETWEEN TERMINAL Y AND Y2 FOR FULL CAPACITY.</p> <p>5. SYSTEM WILL NOT RUN IF TENS INPUT IS NOT JUMPED TO GND. CUSTOMER CAN INTERLOCK SAFETY HERE DRY CONTACTS ONLY.</p> <p>6. JUMPER INSTALLED AT FACTORY.</p> <p>7. THESE COMPONENTS ARE ASSOCIATED TO THE HEATER CIRCUIT: SINGLE STAGE HEAT ONLY. DISREGARD IF THERE IS NO HEATER.</p> <p>8. BT IS THE BEERAGE PFC COILS. MOTORS / AIR HEATER (IF APPL.) OTR AND CRY IS THE COMPRESSOR 1 AND COMPRESSOR 2 RESP.</p> <p>9. ONLY LANGUAGE IN UNITS WITH ECONOMIZER. DISREGARD IF CHARACTER IS OF LABEL NUMBER IS NOT A "Y".</p>		<p>OUTSHEET: K50050 K50081 K50051 K50082 K50059 K50083 K50080</p> <p>REV: 23/55 DATE: 5/2/2023 0</p> <p>DESIGNER: CMBALCOO</p> <p>DATE: 6/14/2022</p> <p>REVISIONS: ORIGINAL</p> <p>UNIT: MGA</p> <p>SCALE: NTS</p> <p>DRAWN BY: D. TALESTRADO</p> <p>APPROVED BY: A. SORIELS</p> <p>PROJECT: 25/30 TON 480-30-60 PLC UNIT W/ ECONOMIZER AND HEAT</p> <p>DATE: 6/14/2022</p> <p>PROJECT NO: CFA300-360AD-P-B2-80</p> <p>0</p>																																													

Chapter 2 Installation

WARNING

Failure to observe and follow Warnings and Cautions and these Instructions could result in death, bodily injury or property damage. Read this manual and follow its instructions and adhere to all Cautions and Warnings in the manual and on the ICE unit.

2.1 Equipment Inspection

Concealed Damage

Inspect all cartons and packages upon receipt for damage in transit. Remove cartons and check for concealed damage. **Important: keep the unit upright at all times.** Remove access panels and examine component parts. Inspect refrigerant circuit for fractures or breaks. The presence of refrigerant oil usually indicates a rupture. If damage is apparent, immediately file a claim with the freight carrier.

Units that have been turned on their sides or tops may have concealed damage to compressor motor mounts or to the oil system. If the unit is not upright, immediately file a claim for concealed damages and follow these steps:

1. Set unit upright and allow to stand for 24 hours with primary power turned on.
2. Attempt to start the compressor after 24 hours.
3. If the compressor will not start, makes excessive noise, or will not pump, return the unit to the freight carrier.

2.2 Installation Requirements

WARNING

Do not remove P-Trap Loop from condensate drain hose. P-Trap Loop must be primed at initial startup before unit is run.

General

1. Inspect unit for completeness. Check for missing parts (e.g. hardware). Refer to the installation kit information in section 2.3.
2. Remove access panels and check for loose wires. Tighten screw connections.
3. Complete and mail the warranty registration card.

You must consider all of the following when choosing the installation site:

1. **Noise.** Install the unit so that the least amount of noise will be transmitted to inhabited spaces.
2. **Condensate Drainage.** Condensate produced during operation must be discharged to a suitable drain.
3. **Placement.**
 - A) Place the unit in a shaded area, if possible.
 - B) Install it above ground for protection against flooding.
 - C) The unit exhausts air. Be sure that the airflow is not impeded by shrubbery or other obstructions.
 - D) When installing multiple units, please note the recommended clearances noted in Table 4.

CAUTION

CFA3240, 3300, 3360 units require additional support. The mounting flanges alone are not adequate.

4. **Airflow Requirements:**

This is maximum external static pressures for duct design. Duct pressure drop not to exceed these values.

Maximum Static Pressures	CFA3240	CFA3300	CFA3360
IWG	1.4	1.6	0.8
Pa	348	398	149

Keep duct lengths as short as possible. Do not obstruct airflow through the unit.

Duct work should be designed and installed in accordance with *all* applicable safety codes and standards. Industrial Climate Engineering strongly recommends referring to the current edition of the National Fire Protection Association Standards 90A and 90B *before* designing and installing duct work. The duct system must be engineered to insure sufficient air flow through the unit to prevent over-heating of the heater element. This includes proper supply duct sizing, sufficient quantity of supply registers, and adequate return and filter areas. Duct work must be of correct material and must be properly insulated. Duct work must be constructed of galvanized steel with a minimum thickness of .019 inches. Duct work must be firmly attached, secured, and sealed to prevent air leakage. See section 2.4 for additional duct work requirements.

5. **Clearances:**

Note the minimum clearances required for proper operation and service. There must be no obstruction 24" from the sides of the unit, or 120" from the front of the unit. Additional clearance is required in high ambient temperatures, greater than 120°F (49°C).

MODEL	MIN. CLEARANCE TO FRONT OF UNIT	MIN. CLEARANCE AROUND SIDES (SINGLE UNIT)	MIN. CLEARANCE BETWEEN UNITS (TWO UNITS)	MIN. SPACE ABOVE UNIT	MIN. SPACE BEHIND UNIT
All Models	10 feet (3 meters)	24 inches (61 cm)	24 inches (61 cm)	24 inches (61 cm)	120 inches (305 cm)

Table 5. Minimum Clearances

6. **Codes:**

Make sure your installation conforms to all applicable electrical, plumbing, building, and municipal codes. Some codes may limit installation to single story structures.

7. **Electrical Supply:**

The power supply must have the appropriate voltage, phase, and ampacity for the model selected. Voltage must be maintained above minimum and below maximum specified values listed below. Refer to the data sticker on the unit for ampacity requirements.

Note: Operation near the Minimum or Maximum limits at extended periods voids the warranty. Power supply should be at nominal Voltage.

Electrical Rating Designations*	A	C	D	Z
Nominal Voltage	208/230	208/230	460	575
Phase	1	3	3	3
Minimum Voltage	197	197	414	518
Maximum Voltage	253	253	506	632

* Letters refer to model number code designations. Refer to page 5.

Table 6. Voltage Limitations

2.3 Installation Materials

The CFA may be shipped with a top bracket and optional lifting brackets. The top bracket provides a method of sealing the top of the unit from water intrusion. The bracket is shipped attached to the top of the unit. Before installing the unit, remove the bracket and reattach as described in Section 2.5

If ordered, the lifting brackets are shipped attached to the back panel of the unit. These brackets provide a method for lifting the unit. The installation of the brackets is described in Section 2.6.

Kit Components:

Accessories:

The package may include other factory-supplied items (optional):

P/N	Description
70705	CommStat 6 2/4 HVAC Controller, Solid State Lead/Lag Controller
S/12087-04	CommStat 6 4/8 HVAC Controller, Solid State Lead/Lag Controller
S/12087-06	CommStat 6 6/12 HVAC Controller, Solid State Lead/Lag Controller
S/07846	CommStat 4 HVAC Controller, Solid State Lead/Lag Controller
S/04581	CommStat 3 HVAC Controller, Solid State Lead/Lag Controller
50123	Digital thermostat. 1 stage heat, 1 stage cool. 7 day programmable. Fan switch: Auto & On. Auto-change over. Keypad lockout. Non-volatile program memory.
93189	Double Deflection Aluminum Supply Grille for the CFA1120/1150 & CFA3150 42½ x 15¼ (1,080mm x 387mm)
93188	Aluminum Return Filter Grille for the CFA1120/1150 & CFA3150 42½ x 21½ (1,080mm x 546mm)
93190	Double Deflection Aluminum Supply Grille for the CFA3180/3240/3300/3360 54½ x 15½ (1,384mm x 394mm)
93191	Aluminum Return Filter Grille for the CFA3180/3240 54½ x 21½ (1,384mm x 546mm)
93192	Aluminum Return Filter Grille for the CFA3300/3360 54½" x 37½" (1,384mm x 953mm)

Additional Items Needed:

Additional hardware and miscellaneous supplies (not furnished by ICE®) are needed for installation.

The list below has the items typically needed for mounting a unit on a wood frame wall structure. Concrete or fiberglass structures have different requirements. ICE cannot recommend a specific method of attaching the air conditioner to the building due to the wide variety of building types, code requirements, wall construction and specific installation conditions. The installation of the air conditioner to the building must take in to account all of these factors and follow best industry practices to provide a safe and secure attachment to the building.

- Mounting bolts for unit mounting flanges. The length needed is typically the wall thickness plus one inch (25 mm).
- Washers
- Hex nuts
- Silicone Sealer to seal around cracks and openings
- Minimum 5 conductor low voltage multicolored wire cable (i.e. thermostat wire)
- Appropriate electrical supplies such as conduit, electrical boxes, fittings, wire connectors, etc.
- High voltage wire, sized to handle the MCA (minimum circuit ampacity) listed on the data plate.
- Over-Current Protection Device sized in accordance with the MFS (maximum fuse size) listed on the unit data plate.

WARNING FIRE HAZARD

Improper adjustment, alteration, service, maintenance or installation could cause serious injury, death and/or property damage.

Installation or repairs made by unqualified persons could result in hazards to you and others. Installation **MUST** conform with local codes or, in the absence of local codes, with codes of all governmental authorities have jurisdiction.

The information contained in this manual is intended for use by a qualified service agency that is experienced in such work, is familiar with all precautions and safety procedures required in such work, and is equipped with the proper tools and test instruments.

2.4 Porting and Duct Work

General Information

Note: The following instructions are for general guidance only. Due to the wide variety of installation possibilities, specific instructions will not be given. When in doubt, follow standard and accepted installation practices, or contact ICE™ for additional assistance.

Wall Openings

Measure the dimensions of the supply and return ports on the unit.

Cut the openings in the exterior wall for the supply and return. **IMPORTANT: All units with electric heat must have 1" (25.4mm) clearance on all four sides of the supply outlet duct flange on the unit. The 1" (25.4mm) clearance must extend on all sides of the supply duct for the first 3 feet (1 meter) from the unit.**

IMPORTANT: ICE™ requires a minimum of 1" (25.4mm) from the surface of any supply ducts to combustible material for the first 3 feet (1 meter) of the duct.

Ducting

Extensions should be cut flush with the inside wall for applications without duct work.

Applications using duct work should be designed and installed in accordance with *all* applicable safety codes and standards. ICE strongly recommends referring to the current edition of the National Fire Protection Association Standards 90A and 90B *before* designing and installing duct work. The duct system must be engineered to insure sufficient air flow through the unit to prevent over-heating of the heater element. This includes proper supply duct sizing, sufficient quantity of supply registers, adequate return and filter area. Ductwork must be of correct material and must be properly insulated. Duct work must be constructed of galvanized steel with a minimum thickness of .019 inches for the first 3 feet (1 meter). Ductwork must be firmly attached, secured and sealed to prevent air leakage. Do not use duct liner on inside of supply duct within 4 feet (122cm) of the unit.

Galvanized metal duct extensions should be used to simplify connections to duct work and grilles. Use fabric boots to prevent the transmission of vibration through the duct system. The fabric must be U.L. rated to a minimum of 197°F (92°C).

Minimum Airflow Requirements

The duct system must be engineered to assure sufficient air flow through the unit even under adverse conditions such as dirty filters, etc.

2.5 Top Flange Installation (See Figure 2)

1. All models have built-in side mounting flanges.
2. Attach the top flange to the top of the air conditioner. The holes in the top of the air conditioner have been predrilled. Remove the 4 screws in these holes and use these screws to attach the top flange to the air conditioner.
3. Apply a bead of silicone sealer on the wall side of the bottom support brackets on the unit. Circle the mounting holes with the silicone bead.

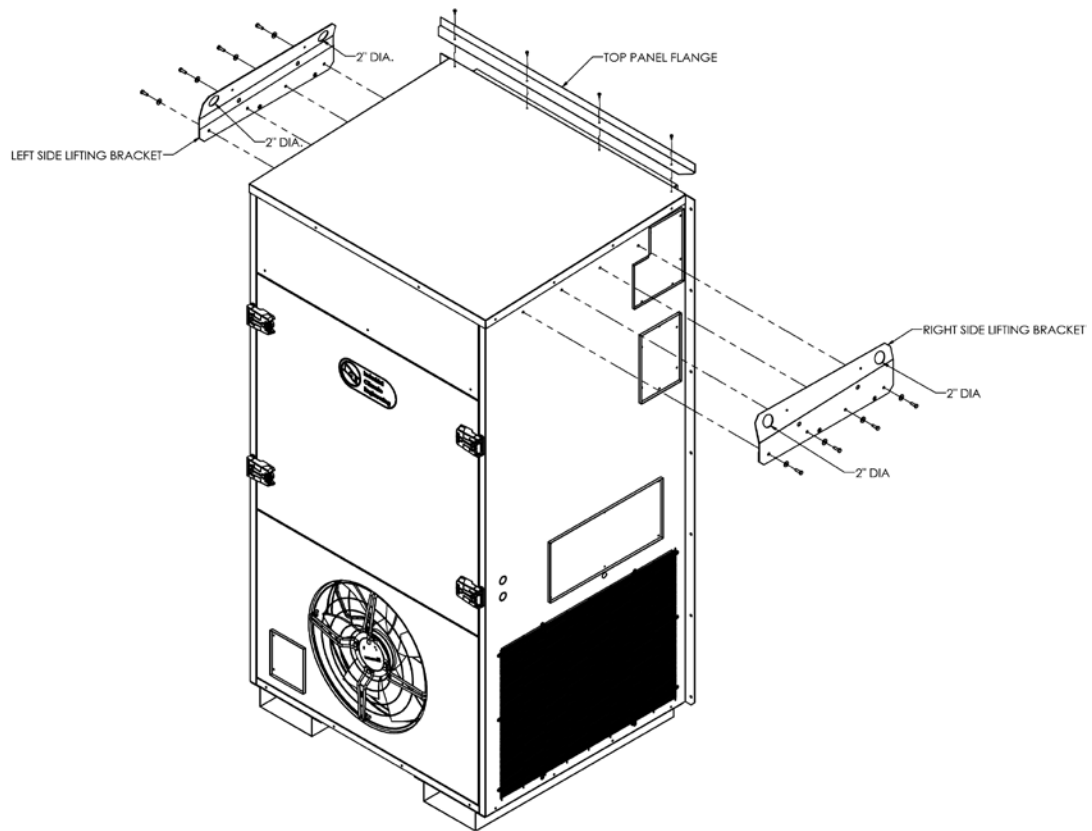

Figure 3. Top Flange and Lifting Bracket Installation (Typical)

2.6 Installing the Optional Lifting Brackets

Lifting brackets are available which can be installed on the top of the side panels. These brackets allow the unit to be picked up using lifting eyes in the brackets. Attach the brackets to the left and right side panels as shown in Figure 3. ICE units are shipped with the 4 screws for attaching the brackets installed in the holes at the top of the side panels. When attaching the brackets, remove and reinstall the screws and make sure the top of the bracket is angled towards the center of the unit.

2.7 Mounting The Unit

1. For wiring into the back of unit, locate the lower of the two knockouts on the wall side of the unit. Drill a one inch hole in the shelter wall to match this opening. Allow sufficient clearance to run 3/4" conduit through the hole and to the unit.
2. Lift the unit into position using an appropriate and safe lifting device.
3. Make sure that the duct flanges are properly aligned with the wall opening. Adjust as necessary.
4. Note the holes in each side flange. Using the holes for guides, drill holes through the wall with a drill bit. Insert the bolts through the flanges. Install nuts and washers on the inside of the shelter. Tighten the bolts to secure the unit.
5. Apply a bead of silicone where the side and top flanges contact the exterior wall.
6. On the inside of the shelter, install the wall sleeves in the supply and return air openings. The sleeves may be trimmed to fit flush with the inside wall.
7. Check the fit of each sleeve to its mating flange for possible air leaks. Apply silicone sealer to close any gaps. Install the air return and supply grilles.

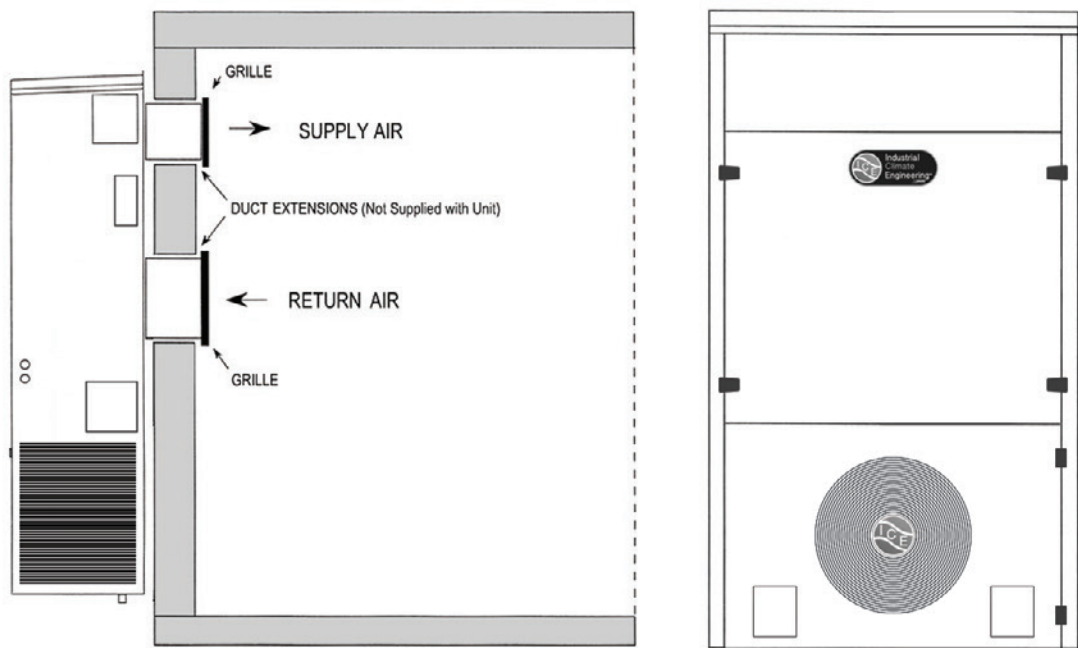

For units with electric heat, a one inch clearance is required around the duct extensions. The duct extensions must be constructed of galvanized steel with a minimum thickness of .019" as per the NFPA standards 90A & 90B.

Figure 4. Air Conditioner Wall Mount Detail

2.8 Compressor Chocks Removal

WARNING

Wooden compressor chocks must be removed and discarded when unit is at final shipping destination. If chocks are not removed damage to compressor or copper system may occur.

Final installer must remove wooden chocks from beneath compressors.

Remove screw from in front of wooden chock, pull chock out from underneath compressor and discard both screw and wooden chock.

Note: There are two chocks to be removed one in the front of the compressor and one at the back of the compressor.

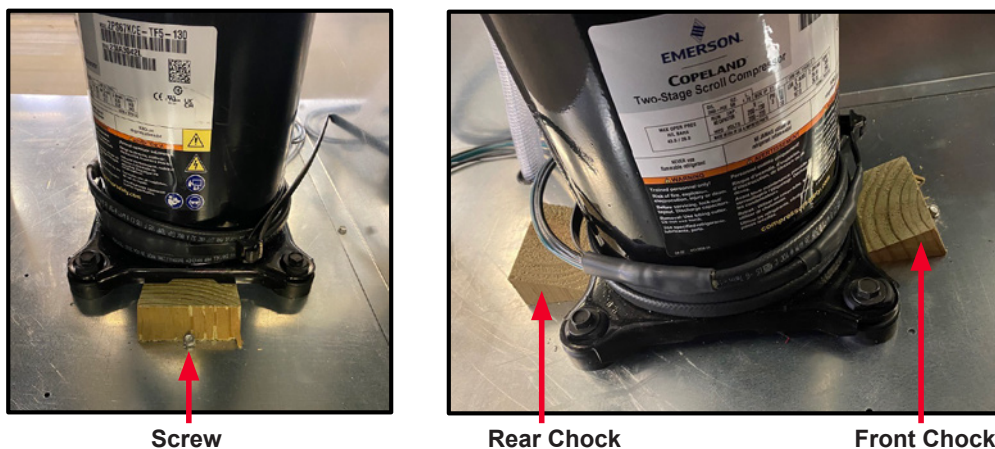

Figure 5. Compressor Chock Removal

2.9 Unit Support Recommendations

Guidelines:

1. For units 15 tons and larger, the base of the unit should be fully supported in transit and in stationary applications to not allow deflection in static or dynamic loading.
2. For units ranging from 7.5 tons to 12.5 tons, the base of the unit should be fully supported in transit to not allow deflection in dynamic loading.
3. The supports should run perpendicular to the fork pockets on the base of the unit.
4. The fork pockets should remain in place for best support.
5. The supports should be 12" on center and include all outer edges.
6. The unit should be mechanically fastened to the support platform to not allow independent movement between the unit and its support.

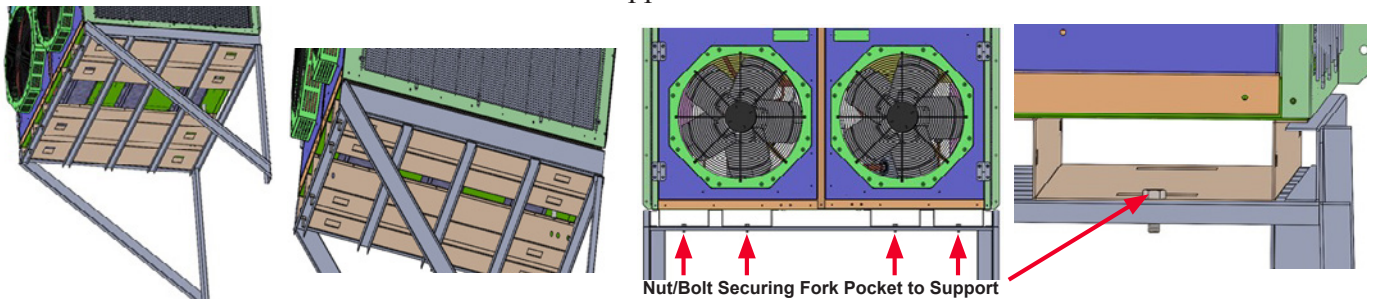

Figure 6a Unit Compression Support Examples

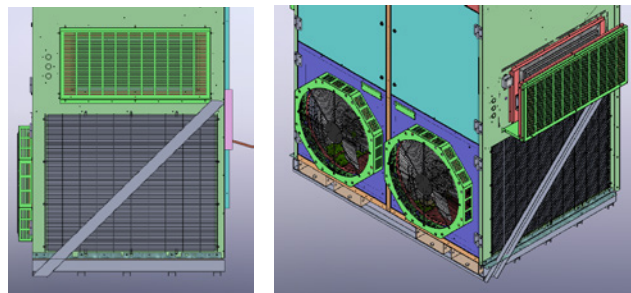

Figure 6b Unit Tension Support Examples

This is a recommendation as it relates to best practices for supporting the unit. Understand that how the unit should be supported varies based on several factors such as available space, supporting structure (concrete, metal), application (static or dynamic) etc. We recommend that the structural integrity of the design be evaluated by a structural expert before integration into the design. *Any decision on use of materials or geometry is the sole responsibility of the customer. Please be advised that supporting the unit along the entire base is required for proper logistics movement. Supporting the unit along the entire base is also required for in place operation on units 25 tons and larger.*

2.10 Electrical Connections

WARNING ELECTRICAL SHOCK HAZARD

Failure to follow safety warnings exactly could result in serious injury, death, and/or property damage.

Turn off electrical power at fuse box or service panel **BEFORE** making any electrical connections and ensure a proper ground connection is made before connecting line voltage.

Important

All electrical work must meet the requirements of local codes and ordinances. Work should be done **only** by qualified persons.

The units may incorporate an internal crankcase heater for compressor protection. **The crankcase heater must be energized for at least 24 hours prior to starting the compressor.**

Scroll compressors, like several other types of compressors, will only compress in one rotational direction. The direction of rotation is not an issue with single-phase compressors since they will always start and run in the proper direction. However, three phase compressors will rotate in either direction depending upon phasing of power. Since there is a 50-50 chance of connecting power in such a way as to cause rotation in the reverse direction, it is imperative to confirm that the compressor is rotating in the proper direction at the initial field start-up of the system. Verification of proper rotation is made by observing that the suction pressure drops and the discharge pressure rises when the compressor is energized. An alternate method of verification for self contained system with small critical refrigerant charges, where the installation of gauges may be objectionable, can be made by monitoring the temperature of the refrigerant lines at the compressor. The temperature should rise on the discharge line while the suction line temperature decreases. Reverse rotation also results in a substantially reduced current draw when compared to tabulated values.

There is no negative impact on durability caused by operating three phase compressors in the reversed direction for a short duration of time, usually defined as less than one hour. However, after several minutes of operation the compressor's internal protector will trip. The compressor will then cycle on the protector until the phasing is corrected. Reverse operation for longer than one hour may have a negative impact on the bearings.

To change the rotation, turn off power to the unit and reverse L1 & L2 at the disconnect in the air conditioner.

The middle front panel provides access to the electrical/control box and to the filters. This panel has hinges on the left and right hand side. This panel should ONLY be opened by using the two hinges on the left side **OR** the two hinges on the right side. **NEVER OPEN ALL FOUR HINGES SIMULTANEOUSLY.**

If all four hinges are opened simultaneously, the front panel will drop and may cause serious injury and damage the panel.

 **DANGER**

NEVER open all four hinges simultaneously. The panel should ONLY be opened by using the two hinges on the left side OR the two hinges on the right side.

High Voltage Wiring

The power supply should have the proper voltage, phase, and ampacity for the selected model.

1. Refer to the electrical data on the data sticker on the unit for field wiring requirements of the unit. Size the incoming power supply lines and the fuse(s) or HACR breaker(s) according to requirements described in the National Electric Code. Run the power conductors through the knockouts on the side or back of the unit. Use appropriate conduit and strain reliefs.

 **CAUTION**

Note: Power supply service must be within allowable range (+10% - 5%) of rated voltage stamped on the unit rating plate. To operate nominal 230/208V unit at 208V, change the transformer line tap from 240V to 208V following the instruction on wiring label in unit.

2. Connect the wires to the input side of the internal breaker or terminal block L1, L2, & L3 for three-phase models.
3. Install the ground wire on the ground lug.
4. For units designed for operation on 208/230V, 60Hz power supply, the transformer is factory wired for a 230V power supply. For a 208V power supply, remove the orange lead from the transformer and connect the red lead. Insulate the orange lead.

CAUTION

The external breaker(s) that provide power to the air conditioner must be sized per the maximum Fuse Size (MFS) shown on the Unit's data label.

Dual Unit Phasing

For applications where one controller operates two units, e.g., the CommStat 4.

1. Wire each unit as described in steps 1 through 4 above.
2. Test for proper phasing as follows:
 - A. Power up the units.
 - B. Using an AC volt meter set to the 300 volt scale, measure voltage between terminal L1 on the compressor contactor of unit #1 and terminal L1 on the compressor contactor of unit #2. If voltage is present, units are wired out of phase and must be rewired.
 - C. If units are not in phase, turn off power and reverse the field power leads connected to the internal circuit breaker on one of the units only.
 - D. Restore power and retest the phase (step B). When the voltage reads "0", the units are in phase.
 - E. Turn off power and proceed.

Low Voltage Wiring

IMPORTANT. The following instructions are generic wiring instructions and may not be applicable for air conditioners with various options. Always refer to the wiring diagram in the air conditioner for the proper method to wire your unit.

1. On single units, pull the low voltage wiring (e.g., 18 gauge 4-conductor Class 2 thermostat wire) from the air conditioners into the thermostat / subbase assembly. See Figure 4a for connections to various thermostats.
2. Mount the thermostat on the wall of the shelter. The thermostat should be located so that the supply air from the unit does NOT blow directly on to the thermostat. Connect the thermostat to the terminal block in the air conditioner as shown in Figure 6a.
3. On dual units, refer to either the ICE CommStat 3 or CommStat 4 *Controller Specification sheet*. Wire the two air conditioners to the Lead/Lag Controller, according to the wiring diagram on the specification sheet.

Remote Signalling: Terminals 5 & 7(N.O.) and 6 & 7 (N.C.) on the air conditioners terminal board are dry contacts which can be used for remote signalling in the event of a/c cutoff on low or high pressure limit.

Continuous fan operation: For continuous indoor fan operation on single units, install a jumper between terminals 8 and 3.

CommStat 4 Lead /Lag HVAC Controller

Please refer to the Product Data sheet for the CommStat 4 controller for complete instructions on installing and programming this controller.

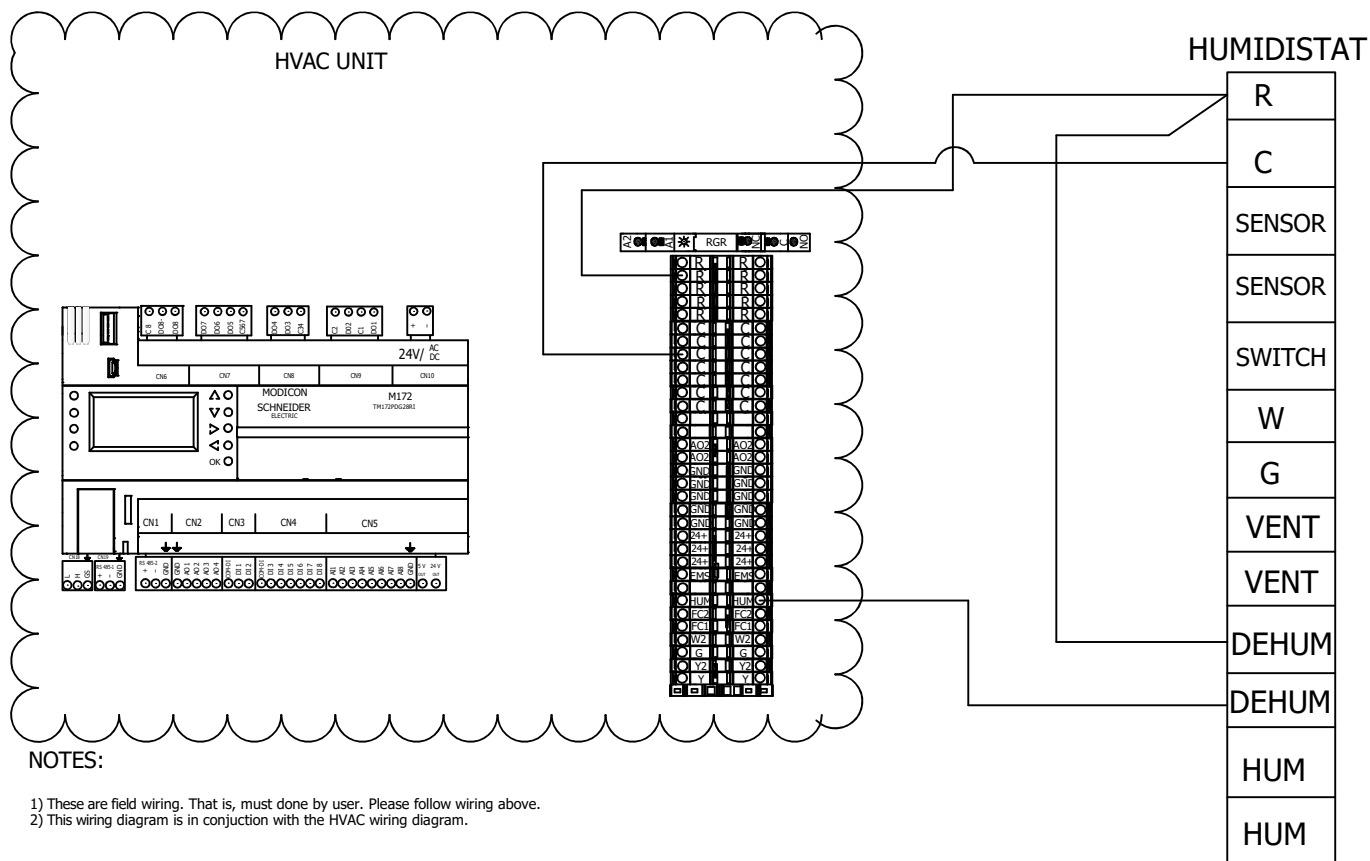

Figure 7a. Humidistat Wiring to a Marvair Air Conditioner with Reheat.

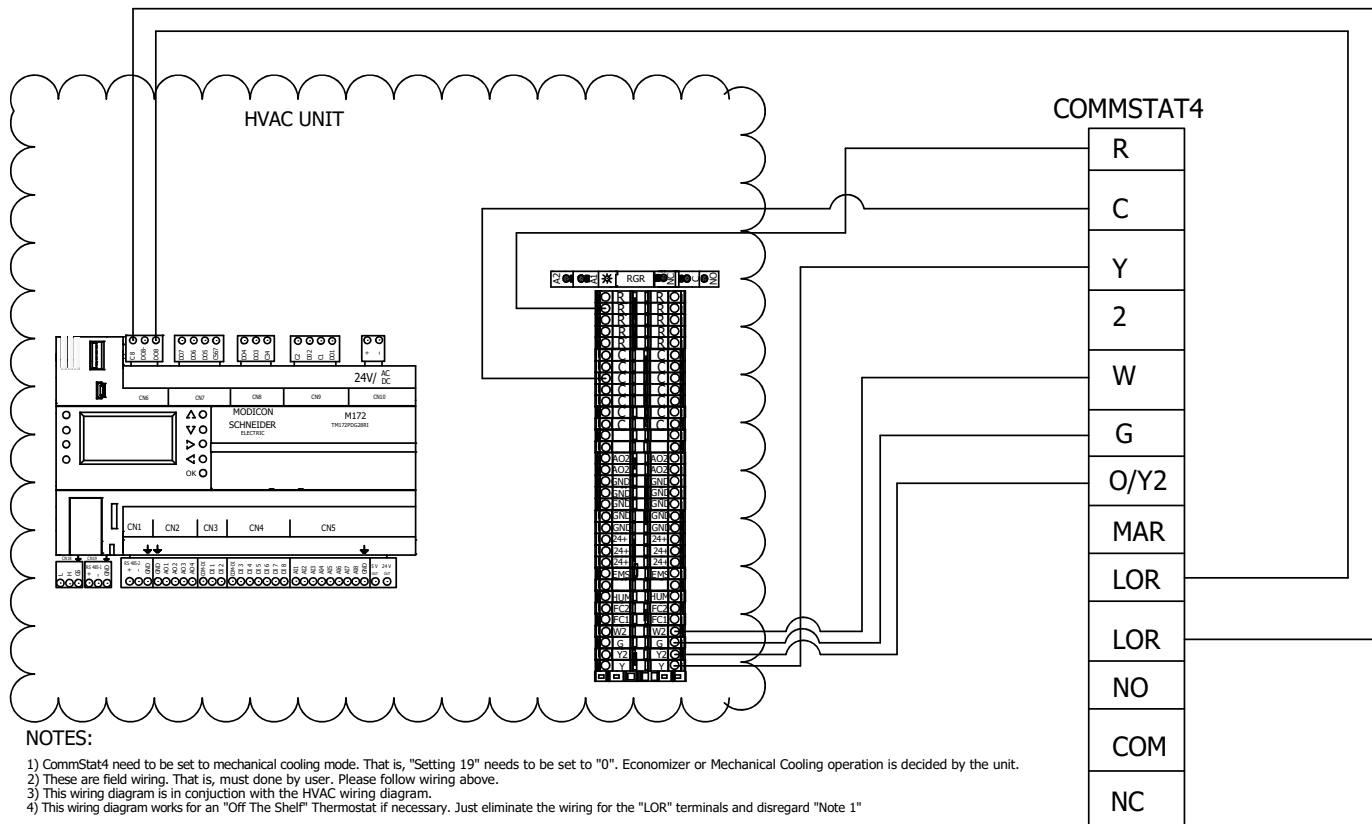

Figure 7b. CommStat 4 Connection Diagram

Chapter 3 Start-Up

3.1 Check-Out of Cooling Cycle

Important: Be sure that the crankcase heater (if used) has been energized for at least 24 hours before starting the unit(s). Double-check all electrical connections before applying power. All air conditioners with scroll compressors running on 3Ø power must be checked for proper rotation during the initial start-up. Please refer to Section 2.8 for determining if the 3Ø compressors are rotating correctly. Incorrect rotation can damage the compressor and is not covered by the warranty

Procedure:

1. Set the cooling set point temperature on the wall thermostat to a point *higher* than the ambient temperature. Set the heating set point temperature to a temperature that is *lower* than the ambient.
2. Set the thermostat system switch in the AUTO position. Nothing should operate at this time.
3. Set the time delay in the control box to three minutes. See Section 1.6.
4. Slowly lower the thermostat's cooling set point temperature until the switch closes. The indoor fan should operate.

Once the indoor fan turns on, allow approximately three minutes for the compressor to start.

5. To stop cooling, slowly raise the thermostat cooling set point to a temperature higher than the ambient.

If the unit fails to operate, refer to the troubleshooting information in Chapter 4.

Follow the same procedure for additional units.

NOTE: The fan purge allows the indoor fan to run for approximately 90 seconds after the compressor is off. This operation provides a small improvement in system rated efficiency.

3.2 Check-Out of Heating Cycle

Procedure: (Applies only to units with resistance elements)

1. Raise the heating set point temperature to a setting which is higher than the ambient temperature. The fan and electric heat should immediately cycle on.
2. Move the system switch to the "OFF" position. All functions should stop.

Chapter 4 Troubleshooting

4.1 Overview

The middle front panel provides access to the electrical/control box and to the filters. This panel has hinges on the left and right hand side. This panel should **ONLY** be opened by using the two hinges on the left side **OR** the two hinges on the right side. **NEVER OPEN ALL FOUR HINGES SIMULTANEOUSLY.**

If all four hinges are opened simultaneously, the front panel will drop and may cause serious injury and damage the panel.

DANGER

NEVER open all four hinges simultaneously. The panel should ONLY be opened by using the two hinges on the left side OR the two hinges on the right side.

A comprehensive understanding of the operation of the air conditioner is a prerequisite to troubleshooting. Please read the Chapter 1 for basic information about the unit.

Our air conditioners are thoroughly tested before they are shipped from the factory. Of course, it is possible that a defect may escape undetected, or damage may have occurred during transportation. However, the great majority of problems result from installation errors.

If you experience difficulties with the unit, please review the installation steps in Chapter 2.

Much time can be saved by taking a thoughtful and orderly approach to troubleshooting. Start with a visual check - are there loose wires, crimped tubing, missing parts, etc? Begin deeper analysis only after making this initial inspection.

The troubleshooting information in this manual is basic. The troubleshooting section contains problem/solution charts for general problems, followed by a compressor section.

Not every problem can be anticipated. If you discover a problem that is not covered in this manual, we would be very grateful if you would bring it to the attention of our service department for incorporation in future revisions.

As always, please exercise caution and good judgement when servicing the air conditioner. Use only safe and proven service techniques. Use refrigeration goggles when servicing the refrigeration circuit.

WARNING

The refrigerant circuit has hot surfaces, and the electrical voltages inside of the unit may be hazardous or lethal. SERVICE MAY BE PERFORMED ONLY BY QUALIFIED AND EXPERIENCED PERSONS.

4.2 Failure Symptoms Guide

PROBLEM/SYMPTOM	LIKELY CAUSE(S)	CORRECTION
<p>A. Unit does not run.</p> <p>NOTE: An internal anti-short-cycle timer will prevent the unit from starting for .2 to 8 minutes following start-up.</p>	<ol style="list-style-type: none"> 1. Power supply problem. 2. Tripped internal disconnect. 3. Shut off by external thermostat or thermostat is defective. 4. Unit off on high or low pressure limit. 5. Internal component or connection failure. 	<ol style="list-style-type: none"> 1. Check power supply for adequate phase and voltage. Check wiring to unit and external breakers or fuses. 2. Check internal circuit protection devices for continuity. 3. Check operation of wall-mounted thermostat. 4. Reset pressure switch. 5. Check for loose wiring. Check components for failure.
<p>B. Unit runs for long periods or continuously; cooling is insufficient.</p>	<ol style="list-style-type: none"> 1. Dirty filter or reduced airflow 2. Low refrigerant. 3. Component failure. 4. Unit undersized for job. 	<ol style="list-style-type: none"> 1. Check air filter(s). Check blower operation. Remove airflow restriction. 2. Check for proper charge and possible refrigerant leak. 3. Check internal components, especially compressor for proper operation. 4. Add additional units for greater capacity.
<p>C. Unit cycles on high/low pressure limit.</p>	<ol style="list-style-type: none"> 1. Loss or restriction of airflow. 2. Restriction in refrigerant circuit. 3. Refrigerant overcharge (following field service) 4. Defective pressure control. 	<ol style="list-style-type: none"> 1. Check blower assembly for proper operation. Look for airflow restrictions, e.g., the air filter. Check blower motor and condenser fan. 2. Check for blockage or restriction, especially filter drier and capillary tube assembly. 3. Evacuate and recharge to factory specifications. 4. Check limit cutout pressures. Control is set to actuate at approximately 60 PSIG (low pressure) and 650 PSIG (high pressure)
<p>D. Unit blows fuses or trips circuit breaker.</p>	<ol style="list-style-type: none"> 1. Inadequate circuit ampacity. 2. Short, loose, or improper connection in field wiring. 3. Internal short circuit. Loose or improper connection(s) in unit. 4. Excessively high or low supply voltage or phase loss (3Ø only) 	<ol style="list-style-type: none"> 1. Note electrical requirements in Chapter 2 and correct as necessary. 2. Check field wiring for errors. 3. Check wiring in unit. See wiring and schematic diagrams. Test components (especially the compressor) for shorts. 4. Note voltage range limitations specific to the compressor troubleshooting section.
<p>E. Water on floor near unit.</p>	<ol style="list-style-type: none"> 1. Obstruction in condensate line. 2. Obstruction or leak in condensate pan. 3. Unit is not level. 	<ol style="list-style-type: none"> 1. Check for clog or restriction. 2. Check pan for leak or blockage. 3. Level unit.
<p>F. No space heating or reduced heating (units equipped with resistance elements)</p>	<ol style="list-style-type: none"> 1. Defective heating element(s). 2. Thermal limit open. 3. Defective heater contactor. 	<ol style="list-style-type: none"> 1. Check resistance element(s) for continuity. 2. Check continuity across thermal limit switch. 3. Check relay for proper operation. Replace if defective.

4.3 Compressor Troubleshooting

NOTE: It is important to rule out other component failures before condemning the compressor.

The following electrical tests will aid diagnosis:

1. **Start-Up Voltage:** Measure the voltage at the compressor contactor during start-up. The voltage must exceed the minimum shown in Table 5, section 2.2, or compressor failure is likely. A low voltage condition must be corrected.
2. **Running Amperage:** Connect a clip-on type ammeter to the (common) lead to the compressor. Turn on the supply voltage and energize the unit. The compressor will initially draw high amperage; it should soon drop to the RLA value or less. If the amperage stays high, check the motor winding resistances.

NOTE: Feel the top of the compressor to see if it has overheated. If it is hot, the internal overload may be open. You may have to wait several hours for it to reset.

3. **Motor Winding Resistances:** Using a digital volt-ohm meter (VOM), measure the resistance across the compressor windings as shown below.

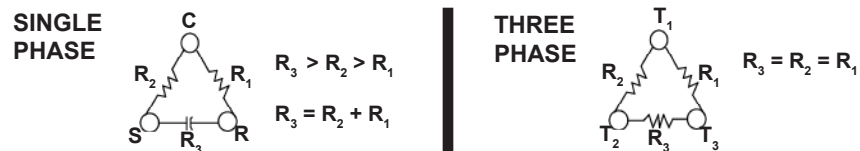

Resistance can be measured as shown above. Any deviation from above values could indicate a defective compressor.

4. **High Voltage/Insulation Test:** Test internal leakage with a megohmmeter. Attach one lead to the compressor case on a bare metal tube and to each compressor terminal to test the motor windings. A short circuit at high voltages indicates a motor defect. Do not do this test under vacuum.
5. On single phase models, check the capacitor by substitution.

4.4 Control Board Diagnosis

The control board (see section 1.6 for a complete description of the control board) has a red diagnostic LED which indicates the lockout fault. The control board will enter into and indicate lockout if either of the fault conditions (LPS or HPS) occur twice.

The compressor contactor must be closed before the first fault condition can be recognized by the control board. The contactor will be closed 3 minutes after the unit is energized and only if cooling is required. The first fault condition will open the contactor and shutdown the unit. The contactor on the unit that has the fault condition must be closed before the second fault condition can be recognized by the control board. The compressor contactor on the unit with the fault condition will close after 3 minutes if the unit is still calling for cooling and if the fault condition no longer exists. If you get a second fault condition, the contactor will open and shutdown the unit. The “red” led will have one blink if the high pressure switch has opened twice and will have two blinks if the low pressure switch has opened twice. The unit must be in the cooling mode (compressor contactor Closed) before a fault condition can occur.

Chapter 5 Maintenance

The middle front panel provides access to the electrical/control box and to the filters. This panel has hinges on the left and right hand side. This panel should **ONLY** be opened by using the two hinges on the left side **OR** the two hinges on the right side. **NEVER OPEN ALL FOUR HINGES SIMULTANEOUSLY.**

If all four hinges are opened simultaneously, the front panel will drop and may cause serious injury and damage the panel.



NEVER open all four hinges simultaneously. The panel should ONLY be opened by using the two hinges on the left side OR the two hinges on the right side.

5.1 Scheduled Maintenance

Industrial Climate Engineering strongly recommends that the air conditioner be serviced a minimum of twice a year – once prior to the heating season and once prior to the cooling season. At this time the filters, evaporator coil, condenser coil, the cabinet, and condensate drains should be serviced as described below. Also at this time, the air conditioner should be operated in the cooling and heating cycles as described in Chapter 3, Start-Up. In addition to this seasonal check-out, the air conditioner should be maintained as follows:

Air Filter

Replace the air filter whenever it is visibly dirty. Never operate the unit without the filter in place. Depending upon the configuration of your unit, access to the filter can be either from the outside through the hinged door or from the return grille on the inside of the building.

Evaporator

If the evaporator becomes clogged or dirty, it may be cleaned by careful vacuuming or with a commercial evaporator cleaning spray. **DO NOT** use a solvent containing bleach, acetone, or flammable substances. Turn off power before cleaning. Be careful not to wet any of the electrical components. Be sure the unit has dried before restarting.

Condenser

Periodically inspect the outdoor condenser coil and the cabinet air reliefs for dirt or obstructions. Remove foreign objects such as leaves, paper, etc.

If the condenser coil is dirty, it may be washed off with a commercial solvent intended for this purpose. **TURN OFF POWER BEFORE CLEANING!** Be sure that all electrical components are thoroughly dry before restoring power. Use a fin comb of the correct spacing to straighten mashed or bent fins.

Cabinet

The cabinet may be cleaned with a sponge and warm, soapy water or a mild detergent. Do not use bleach, abrasive chemicals or harmful solvents.

Drains

The condensate is drained from the condensate pan through two drains – one on the left side of the pan and the other on the right side. The condensate lines drain to the outside at the bottom of the unit through the base pan. Each of the drain lines is looped to form a trap.

Regularly check each drain line to make sure it is not obstructed. If a commercial drain solvent is used, flush out the drain pan and system with sufficient water to remove the solvent. Some solvents can cause the drain pan to corrode.

Lubrication

The condenser fan motor(s) and the evaporator blower motor(s) never require oiling.

Chapter 6 Warranty

6.1 Industrial Climate Engineering Limited Product Warranty

Marvair Inc., warrants its products to be free from defects in materials and workmanship under normal use to the original purchaser for the period of time in the table below. If any part of your product fails within 12 months from start-up, or 18 months from shipment from the factory, whichever comes first, Marvair, Inc. will furnish without charge, EXW Cordele, Georgia, the required replacement part. The owner must provide proof of the date of the original start-up. The contractor's invoice, the certificate of occupancy, or similar documents are examples of acceptable proof of the date of the original start-up.

Marvair, ICE, Eubank Products
90 Days ¹ w/Flat Rate Labor ² (See Marvair, ICE, Eubank Flat Rate Labor Guidelines)
1 Year Parts ^{2,3}
5 Years Compressor ²

¹If any part of your Marvair, Inc. unit fails within 90 days of the commencement of the warranty, Marvair, Inc. will furnish without charge, EX Works, Cordele, Georgia, the required replacement part and pay for the labor to replace the part in accordance with the Marvair, Inc. Flat Rate Labor Guidelines.

²All OTR (over the road) applications that are moved from one location to another: Factory Warranty applies only up to the point of initial start-up and test at all OEM manufacturing locations or subsequent facility. Once it goes into OTR service, the warranty expires immediately for compressor and sealed system components. This OTR exemption does not apply to relocatable classrooms, construction or office trailers.

³All warranty replacement parts shall be shipped Ground only. Expedited shipping is available upon request for additional cost.

The responsibility of the equipment owner includes:

1. To operate the equipment in accordance with the manufacturer's instructions.
2. To provide easy accessibility for servicing.
3. To check and reset any circuit breaker(s) and/or disconnect(s) prior to calling for service.
4. To keep the unit clean and free of dirt and containment and replace filters as required.
5. To keep the outdoor coil clean and free of leaves, paper, or other debris.
6. To pay the charges incurred when any of the above have not been done.
7. To pay for repair or replacement of any material or part other than those within the Marvair unit or controller.

Marvair, Inc., will not be responsible for labor after 90 days, transportation costs, delays or failures to complete repairs caused by events beyond our control (labor hours incurred due to required site-specific training, time waiting to gain access, or extended drive time for remote sites). This warranty does not cover:

1. Any transportation, related service labor, diagnosis calls, filter, driers, refrigerant, or any other material charges.
2. Damages caused by shipping, accident, abuse, negligence, misuse, fire, flood, or Acts of God.
3. Damages caused by operating or staging the unit in a corrosive environment.
4. Damages caused by improper application of the product.
5. Damages caused by failing to perform proper routine maintenance.
6. Expenses incurred for erecting, disconnecting or dismantling the product or installing the replacement part(s).
7. Products not installed or operated according to the included instructions, local codes, and good trade practices.
8. Products moved from the original installation site.
9. Products lost or stolen
10. Consequential damages or incidental expenses including losses to persons, property or business.
11. Modifications to original unit after it leaves the factory, such as breaking into any part of the sealed systems unless authorized in advance in writing by Marvair, Inc..
12. Damages as a result of operating as a construction site cooler / dehumidifier.

When labor (first 90 days only) is required, it must be performed during normal working hours (8:00 AM - 5:00 PM) Monday - Friday and must be performed by Marvair, Inc., personnel or a designated Service Representative.

The owner of the product may ship the allegedly defective or malfunctioning product or part to Marvair, Inc., at such owner's expense, and Marvair, Inc., will diagnose the defect and, if the defect is covered under this warranty, Marvair, Inc., will honor its warranty and furnish the required replacement part. All costs for shipment and risk of loss during shipment of the product to Marvair, Inc., and back to the owner shall be the responsibility and liability of the owner. Upon written request by an owner, Marvair, Inc., may arrange for remote diagnosis of the allegedly defective or malfunctioning product or part but all costs for transportation, lodging and related expenses with regard to such diagnostic services shall be the responsibility and liability of the owner.

An owner requesting performance under this Warranty shall provide reasonable access to the allegedly defective or malfunctioning product or part to Marvair, Inc., and its authorized agents and employees.

THIS WARRANTY CONSTITUTES THE EXCLUSIVE REMEDY OF ANY PURCHASER OF A MARVAIR HEAT PUMP OR AIR CONDITIONER AND IS IN LIEU OF ALL OTHER WARRANTIES, EXPRESSED OR IMPLIED, INCLUDING, WITHOUT LIMITATION, ANY IMPLIED WARRANTY OF MERCHANTABILITY OR FITNESS FOR USE, TO THE FULLEST EXTENT PERMITTED BY LAW. IN NO EVENT SHALL ANY IMPLIED WARRANTY OF MERCHANTABILITY OR FITNESS FOR USE EXCEED THE TERMS OF THE APPLICABLE WARRANTY STATED ABOVE AND MARVAIR SHALL HAVE NO OTHER OBLIGATION OR LIABILITY. IN NO EVENT SHALL MARVAIR BE LIABLE FOR INCIDENTAL OR CONSEQUENTIAL DAMAGES OR MONETARY DAMAGES.

THIS WARRANTY GIVES YOU SPECIFIC LEGAL RIGHTS, AND YOU MAY ALSO HAVE OTHER RIGHTS WHICH VARY FROM STATE-TO-STATE. Some states do not allow limitations or exclusions, so the above limitations and exclusions may not apply to you.

Chapter 7 Start-Up Check List

The middle front panel provides access to the electrical/control box and to the filters. This panel has hinges on the left and right hand side. This panel should ONLY be opened by using the two hinges on the left side **OR** the two hinges on the right side. **NEVER OPEN ALL FOUR HINGES SIMULTANEOUSLY.**

If all four hinges are opened simultaneously, the front panel will drop and may cause serious injury and damage the panel.



NEVER open all four hinges simultaneously. The panel should ONLY be opened by using the two hinges on the left side OR the two hinges on the right side.

7.1 Start-Up & Commissioning Form

Please complete the information on this form and return to ICE by mail or fax. The mailing address and fax number can be found at the end of the form.

A. Equipment Information

Date: _____ Equipment Owner _____

Installing Company: _____ Installer: _____

Address: _____ State _____

City: _____

ICE Air conditioner: Model No. _____

Serial No. _____

Compressor: Model No. _____

Serial No. _____

Compressor: Model No. _____

Serial No. _____

B. Pre-Start Up

Is there any shipping damage? Yes No

If so, where? _____

Will this damage prevent starting the unit? Yes No

Check Power Supply, does it agree with data sticker on air conditioner? Yes No

Has the ground wire been connected? Yes No

Has the circuit protection been sized and installed properly? Yes No

Controls

Are the thermostat control wiring connections made and checked? Yes No

Are all wiring terminals (including main power supply) tight? Yes No

If unit has a crankcase heater, has it been energized for 24 hours? Yes No

On a 208/230 v. units is control transformer (24 AC) wired for correct voltage? Yes No

Condensate Section

Has water been placed in drain pan to confirm proper drainage? Yes No
Are correct filters in place? Yes No

Refrigerant Piping

If leaks are found, report any leaks to ICE Warranty Service Dept.

C. Check Rated Voltage at Terminal Block for Imbalance before starting of Unit.

- 208/230V 1 Phase 208/230V 3 Phase 460V 3 Phase
- 380V 3 Phase 50Hz. 575 3 Phase 60 Hz.

Measured Line to Line Volts L1&L2 _____ V. L1&L3 _____ V. L2&L3 _____ V.

$(L1\&L2 + L1\&L3 + L2\&L3)/3 = \text{Avg. Voltage} = \underline{\hspace{2cm}}$

Max. Deviation from avg. voltage = _____ volts

Voltage imbalance = $(100 \times \text{Max. Deviation})/\text{avg. Voltage} = \underline{\hspace{2cm}}\%$

A voltage deviation greater than 2% with the unit running should be addressed and corrected. Excess voltage deviation can cause the compressor to overheat and to operate inefficiently.

Example:
$$\frac{\text{Maximum Deviation from Average Voltage} \times 100 \text{ (for Percent)}}{\text{Average voltage}}$$

Measured Voltages:

- L1 & L2 = 241 Volts
- L1 & L3 = 243 Volts = $717 / 3 = 239$ Average Voltage
- L2 & L3 = 233 Volts

$239 - 233 = 6$
 $100 \times 6/239 = 2.5\%$ Voltage Unbalance

Three phase units only check fan & compressor rotation.

D. Heating Mode Check & Record Readings

	Circuit 1	Circuit 2 <i>(if applicable)</i>
Room Temperature	_____	_____
Outside Temperature	_____	_____
Evap. Entering Air DB Temp	_____	_____
Evap. Entering Air WB Temp	_____	_____
Evap. Leaving Air DB Temp	_____	_____
Evap. Leaving Air WB Temp	_____	_____
Heater Contactor Amps (L1)	_____	_____
Heater Contactor Amps (L2)	_____	_____
Heater Contactor Amps (L3)	_____	_____

E. Cooling Mode Check & Record Refrigerant Pressures

Recheck voltage imbalance in cooling mode:

Measured Line to Line Volts L1&L2 _____ V. L1&L3 _____ V. L2&L3 _____ V.

$(L1\&L2 + L1\&L3 + L2\&L3)/3 = \text{Avg. Voltage} = \underline{\hspace{2cm}}$

Max. Deviation from avg. voltage = _____ volts

Voltage imbalance = $(100 \times \text{Max. Deviation})/\text{avg. Voltage} = \underline{\hspace{2cm}}\%$

After 10 minutes of compressor operation, record the following:

	Circuit 1	Circuit 2 <i>(if applicable)</i>
Room Temperature	_____	_____
Outside Temperature	_____	_____
Suction Pressure	_____	_____
Suction Line Temperature	_____	_____
Discharge Pressure	_____	_____
Discharge Line Temperature	_____	_____
Entering Condenser Air	_____	_____
Leaving Condenser Air	_____	_____
Evap. Entering Air DB Temp	_____	_____
Evap. Entering Air WB Temp	_____	_____
Evap. Leaving Air DB Temp	_____	_____
Evap. Leaving Air WB Temp	_____	_____
Compressor Amps (L1)	_____	_____
Compressor Amps (L2)	_____	_____
Compressor Amps (L3)	_____	_____

Notes:

Appendix A: PLC SetUp and Operation

These instructions are intended to assist users in navigating through the different PLC screens as well as understanding the variables located on each screen.

Note:

1. Screen numbers are referenced from “Digital Inputs” which is the first screen seen when PLC’s display is populated.
2. Normal mode represents the state in which there are no active faults and no user emergency functionality is triggered.

Navigation

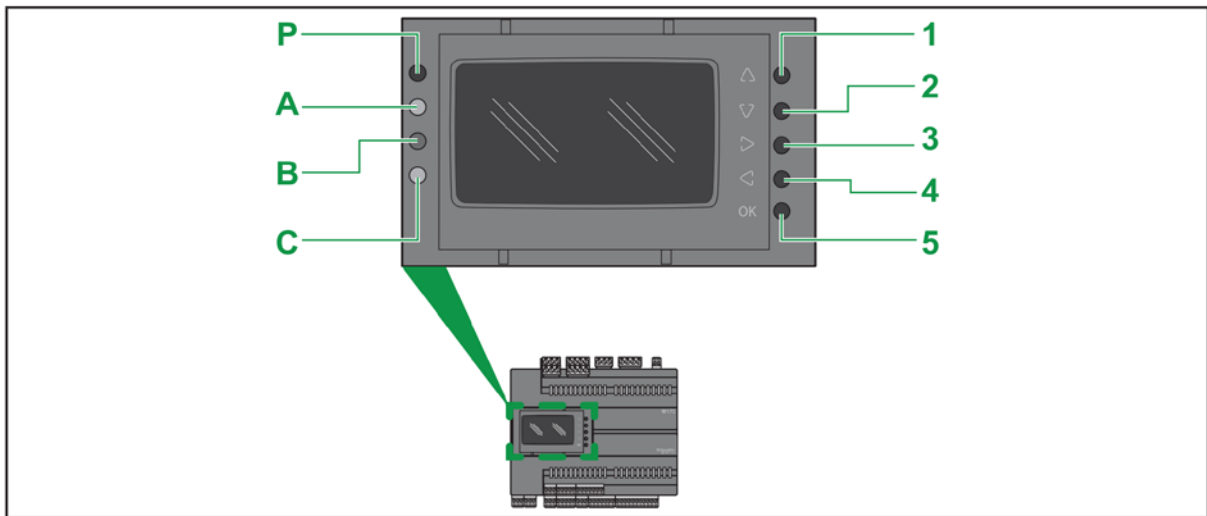

The keys can be programmed from the controller application. In the following table are described the keys default setting (keys are configurable through the logic controller).

Each control can be adjusted by using the directional buttons. Note: In “Edit Mode”, the cursor flashes under the value that is going to be modified by the user.

No.	Key	Press Once (press and release)
1	△ UP	<ul style="list-style-type: none"> • Scroll Up • Increase/Modify a Value
2	▽ DOWN	<ul style="list-style-type: none"> • Scroll Down • Decrease/Modify a Value
3	▷ RIGHT	<ul style="list-style-type: none"> • Move Cursor Right In Edit Mode • Back to Next Menu/Page
4	◁ LEFT	<ul style="list-style-type: none"> • Move Cursor Left In Edit Mode • Go Back to Previous Menu/Page • Press and Hold to Exit Edit Mode Without Saving
5	OK	<ul style="list-style-type: none"> • Enter/Exit Edit Mode • Confirm Operation

Digital Inputs

This screen correlates each PLC’s digital input to the specific input that is being monitored. It also provides the status of each input. This drastically expedites troubleshooting which consequently decreases downtime of the unit. The “Digital Input” is the first screen that will populate on the PLC’s display when the PLC has loaded.

Figure 1 shows the digital input screen when all pressure switches are properly functioning, and the emergency shutdown is closed.

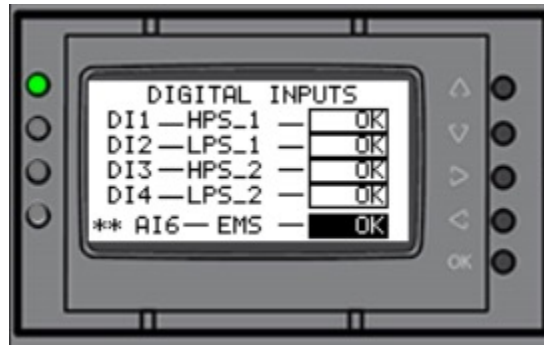

Figure 1

Table 1 shows the designations for each input and their status based on the input.

Digital Input	Designation	Normal Status	Fault Status
1	HPS_1 [HIGH PRESSURE - CIRCUIT 1]	OK [CLOSED]	FAULT [OPEN]
2	LPS_1 [LOW PRESSURE - CIRCUIT 1]	OK [CLOSED]	FAULT [OPEN]
3	HPS_2 [HIGH PRESSURE - CIRCUIT 2]	OK [CLOSED]	FAULT [OPEN]
4	LPS_1 [HIGH PRESSURE - CIRCUIT 2]	OK [CLOSED]	FAULT [OPEN]
AI6*	EMS [SHUTDOWN/USER INTERLOCK]	OK [CLOSED]	FAULT [OPEN]

Table 1

Note that pressure faults only affect the operation of the respective circuit.

Operational Request

This screen maps each thermostat input to a digital input on the PLC. The state of each input is monitored which gives the end user the ability to see what operation is being requested by the controller (Thermostat, Lead/Lag, etc).

Figure 2 shows the operation request screen when stage 1 cooling is being requested.

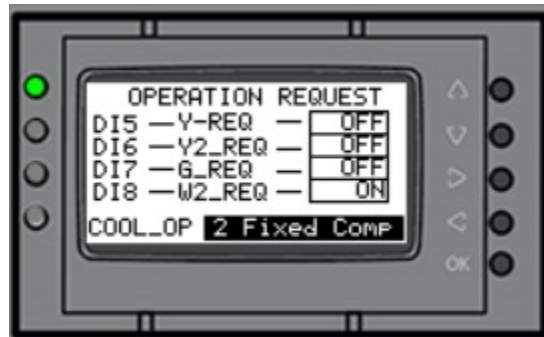

Figure 2

Table 2 shows the designations for each input and their status based on the input.

Digital Input	Designation	Active	Inactive
5	Y-REQ [STAGE 1 COOLING REQUEST]	ON	OFF
6	Y2-REQ [STAGE 1 COOLING REQUEST]	ON	OFF
7	G-REQ [FAN ONLY REQUEST]	ON	OFF
8	W2-REQ [HEATING REQUEST]	ON	OFF

Table 2

“COOL_OP” represents the setting on the PLC which allows the HVAC unit to operate with a different number of cooling stages.

1. **2 Fixed Compressor** – This allows the unit to operate with 2 independent cooling stages. Therefore, allows the stages to be turned on as needed which effectively provides a more optimal management of the temperature of the space being cooled. (Default)
2. **5 Stages** – This allows the compressor to operate with 5 stages of cooling. Note that HVAC unit must be equipped with necessary compressors and associated controls for this work. A indicator is Character “15” of model number is “2” for units with this capability.

Digital Output

These screens show the status of each digital output as well as a description of the respective output.

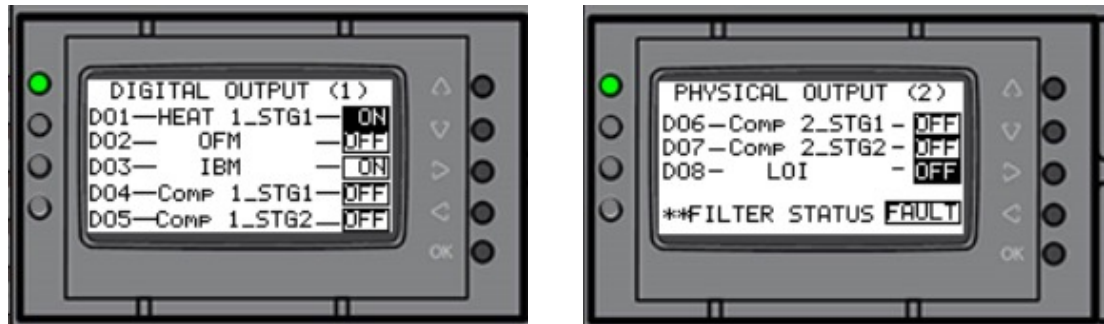

Note: In normal operation, the status of “DO8” is “OFF”. If “DO8” is “ON” all outputs are turned off.

Psychrometrics 1|2

This screen monitors some air conditioning of the indoor and outdoor air as well as provide the user with the ability to calibrate these numbers with the adjacent respective offset.

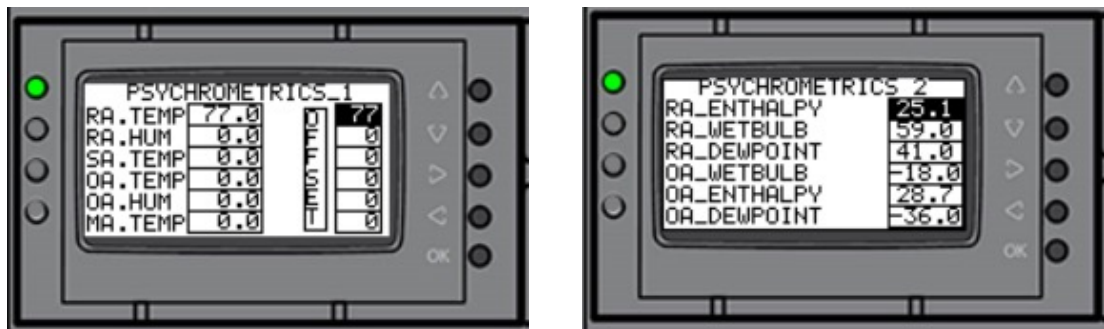

Table 3 shows the description of each variable displayed on screen above.

Variable	Description
RA¹ TEMP	Space Temperature measured
RA¹ HUM	Space Humidity measured
SA TEMP	Supply Air Temperature
OA² TEMP	Outdoor Temperature measured
OA² HUM	Outdoor Humidity measured
MA TEMP	Mixed Air Temperature measured
¹ RA = Room Air ² OA = Outside Air	

Table 3

Note:

1. “SA TEMP” and “MA TEMP” are the same in most designs unless specified otherwise.
2. “OA TEMP”, “OA HUM” and SA TEMP are only monitored in units with Economizers.

Motor Operation

This screen allows the end user to configure the operation of the air movers in the HVAC unit.

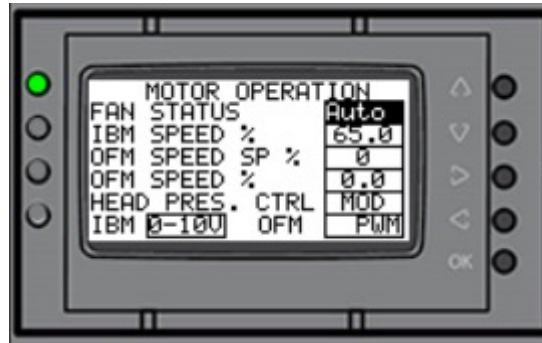

1. **FAN STATUS** – This setting manages the indoor motor operation.
 - b. *AUTO (Default)* – This setting allows the indoor blower to run based on a request for an air conditioning operation. Once the operation terminates, the blower goes off after the 90 second time off delay.
 - c. *ON*– This setting forces the blower to run continuously irrespective of an air conditioning operation. The blower operation only terminates if and emergency shutdown input is triggered.
2. **IBM SPEED %** – The speed at which the PLC is commanding the indoor fan motor to operate.
3. **OFM SPEED %** – The speed at which the PLC is commanding the condenser fan to operate at.
4. **OFM SPEED SP** – This setting forces outdoor motor to operate at a speed designated by the user. Note that this is only applicable if the outdoor motor being used is an EC motor and “*HEAD PRES. CTRL*” is set to “*CYC*”. (Default to 80%)
5. **HEAD PRES. CTRL** – This allows the end user to either modulate the outdoor fan or cycle the outdoor fan to manage the head pressure of the HVAC unit.
 - a. *MOD (Default)* – Allows the condenser fan to modulate based on Head Pressure. As the head pressure rises, the condenser fan increases and vice versa. The system modulates to maintain a liquid line temperature of approximately 80 - 85°F.
 - b. *CYC* – Allows the condenser fan to cycle on at the speed set a “*OFM SPEED SP*”. The fan operates in an ON/OFF manner to maintain a liquid line temperature of about 90 - 95°F on average.
6. **Control Signals** – This allows the end user to set the control signal for motors. These are factory configured and should not be changed. If configured incorrectly, it will result in the motors not operating. IBM and OFM represents the options for the Indoor Blower Motor and Outdoor Fan Motor respectively.
 - g. *0-10VDC (Default for IBM)* – Set to be PWM for units 6 Tons and smaller
 - h. *WM* – (Default for OFM)

IBM SPEED

This allows the end user to set the operational speed of the Indoor Blower Motor for each air conditioning operation. If the unit is only 2 stages, “STG 2” represents first stage cooling speed and “STG 5” represents second stage cooling speed.

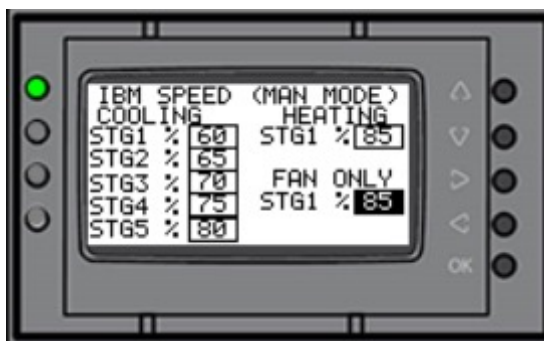

Default Values:

Cooling (%)

- Stage 1: 50
- Stage 2: 55 (1st Stage Speed – 2 Fixed Compressor Setting. See “COOL_OP”)
- Stage 3: 60
- Stage 4: 60
- Stage 5: 65 (2nd Stage Speed– 2 Fixed Compressor Setting. See “COOL_OP”)

Heating (%)

- Stage 1: 60

Fan Only (%)

- Stage 1: 60

ECONOMIZER SETUP

This allows the end user to configure the economizer operation. See *Sequence of Operation* for in depth explanation of the function

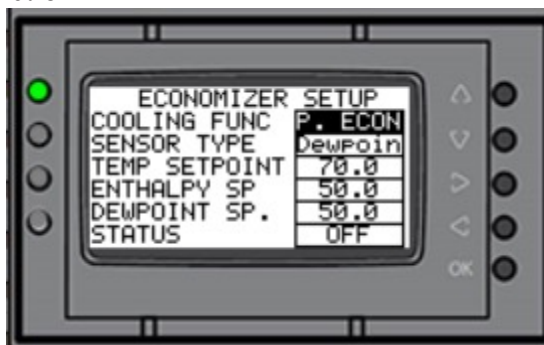

1. **COOLING FUNC** – Allows the selection of the various cooling approach.
 - b. *MECH* – Mechanical Cooling (DX) Only. Cools space by activating the compressors without allowing infiltration of outside air.
 - c. *ECON* – Basic Economizer. Attempts to Cools space initially by allowing infiltration of outside air without operating the compressor first. Activates compressor and a stop the infiltration of outside air if outside air cannot manage the heat load.
 - d. *P. ECON* (Default) – Partial Economizer. Attempts to Cools space initially by allowing infiltration of outside air without operating the compressor first. Activates compressor as well as continue to allow infiltration of outside air to manage the heat load.
2. **SENSOR TYPE** – Allows the selection of the parameters necessary for economizer operation.
 - c. Dry-bulb
 - d. Enthalpy
 - e. Dewpoint (Default)

3. **TEMP SETPOINT** – Temperature Differential required between the space and the outside air at which economizing is allowed. (Default = 70.0°F)
4. **ENTHALPY SETPOINT** – Enthalpy Differential required between the space and the outside air at which economizing is allowed. (Default = 50%)
5. **DEWPOINT SP.** – Dewpoint Setpoint is maximum dewpoint required between the space and the outside air at which economizing is allowed. (Default = 55°F)
6. **STATUS** – This tells if the HVAC unit is economizing or not.
 - a. *ON* – Economizing
 - b. *OFF* – Not economizing

DAMPER SETUP

Allows the end user to configure and monitor damper operation

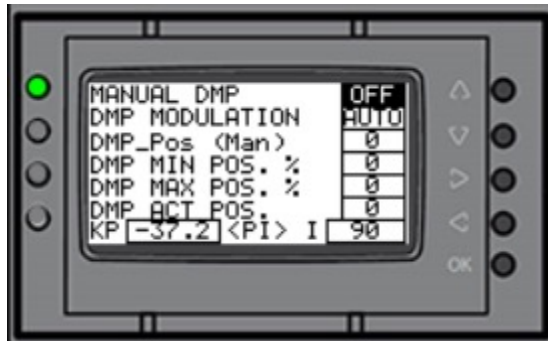

1. **MANUAL DMP** – Allows user to control the position of the damper manually
 - b. *OFF* (Default) – Dampers are controlled automatically
 - c. *ON* – Damper goes to the position configured in “*DMP_Pos (Man)*”.
2. **DMP MODULATION** – Allows the selection of modulation during economizing or go to a fix position configured in “*DMP_Pos (Man)*”.
 - c. *AUTO* (Default) – Modulates to maintain a 55°F supply air temperature
 - d. *MAN* – Damper position dictated by “*DMP_Pos (Man)*”.
3. ***DMP_Pos (Man)*** – Allows the end user to define a position for the Damper. Note that immediate operation is dependent on previous settings. (Default = 0)
4. ***DMP MIN POS %*** – Minimum allowed damper position (Default = 20%)
5. ***DMP MAX POS %*** – Maximum allowed damper position (Default = 55%)
6. ***DMP ACT POS.*** – Requested damper position.
7. Control Signal Response tuning values. Tuned at factory. DO NOT CHANGE
 - a. *Proportional Value (KP)* = -37.2 (Default)
 - b. *Integral Value (I)* = 90 (Default)

REFRIGERATION

Allows the user to monitor the liquid line temperature of each refrigeration circuit as well as offset the measured values.

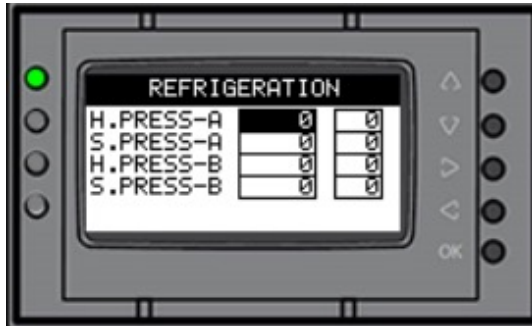

1. **H. PRESS** – A|B represents the liquid line temperature of circuit 1 and 2 respectively.
2. **S. PRESS** – A|B represents the suction pressure of circuit 1 and 2 respectively. (Not monitored)
Note: The system modulates to maintain a liquid line temperature of 100°F.

THERMOSTAT (T-STAT)

This screen allows end users to setup the onboard thermostat. Note that this is only applicable if the associated sensors are purchased with the device. Note that Thermostat only works if a local sensor is purchased with the HVAC unit.

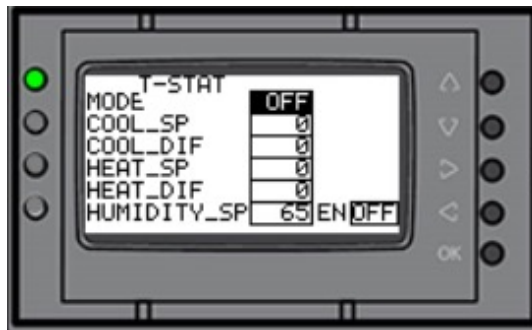

1. **MODE** – This allows the end user to select the allowable operation on the thermostat. See *Sequence of Operation* for explanation of the operation.
 - a. **OFF** (Default) – Does not allow cooling, heating or dehumidification based on the sensor values measured. These operations can only be triggered by digital inputs. See digital inputs above for the respective inputs.
 - b. **COOL** – This setting only allows cooling operation only.
 - c. **HEAT** – This setting will only allow heating operation only.
 - d. **AUTO** – This setting will allow both cooling and heating operation to occur.
2. **COOL_SP** – This variable represents the reference value used for triggering the cooling operation. (Default = 75°F)
3. **COOL_DIF** – This variable represents the allowable differential between each stage of cooling. For example. If [**COOL_SP** = 80 and **COOL_DIF** = 2], First Stage is triggered at 80, and second stage would be triggered at 82. (Default = 4°F)
4. **HEAT_SP** – This variable represents the reference value used for triggering the heating operation. (Default = 60°F)
5. **HEAT_DIF** – This variable represents the allowable differential between each stage of Heating. For example. If [**HEAT_SP** = 50 and **HEAT_DIF** = 2], First Stage is triggered at 50, and second stage would be triggered at 48. (Default = 4°F)

6. Humidity

- a. **HUMIDITY_SP** – This variable represents the reference value used to trigger the dehumidification operation. (Default = 50%)
- b. **EN** – This variable allows the end user to Enable or Disable the dehumidification operation. Note that this is unit dependent and supporting utility should be capable of supporting the full load capacity of the HVAC unit. See SPPE value on data label.
 - i. *ON* (Default) = Enabled
 - ii. *OFF* = Disable

COMMUNICATION SETUP

This screen allows end user to setup up some communication parameters. Note that the IP address set here is the IP address of the device and the address that would be used to access the local web server on the PLC. [DEFAULT VALUES SHOWN ON SCREEN ILLUSTRATION BELOW]

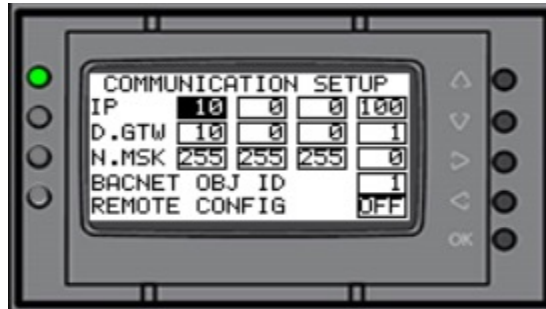

1. REMOTE CONFIG

- b. *OFF* – Allows the IP address to be configured locally
- c. *ON* – Allows the IP address configuration to be configured remotely

Web Server Default Credentials

Username: *administrator*

Password: *marvair01*

Use the IP address in any web server while connected to the PLC via Ethernet to access the local web server on the PLC. Note that the PLC and the device being used to access the webserver MUST be on the same subnet for the user to gain access.

PLC GENERAL PURPOSE INPUT/OUTPUT

Analogue Input		
Name	Variable	Type
AIL1	Liquid Line Temp – Circuit 1	NTC
AIL2	Liquid Line Temp – Circuit 2	NTC
AIL3	Outdoor Air Temperature	VOLTAGE [0-10VDC]
AIL4	Outdoor Air Humidity	VOLTAGE [0-10VDC]
AIL5	Mixed Air Temperature	NTC
AIL6	Emergency Shutdown Input	BOOL [N.C]
AIL7	Dirty Filter	BOOL [PLC GND]
AIL8	Dehumidification	BOOL [PLC GND]
Analogue Output		
Name	Variable	Type
AOL2	DAMPER MOTOR SIGNAL	0-10VDC
AOL3	OUTDOOR MOTOR SIGNAL	PWM/0-10VDC
AOL4	INDOOR MOTOR SIGNAL	PWM/0-10VDC
Digital Input		
Name	Variable	Type
DIL1	HIGH PRESSURE SWITCH 1 [HPS1_INPUT]	BOOL [24 VAC]
DIL2	LOW PRESSURE SWITCH 1 [LPS1_INPUT]	BOOL [24 VAC]
DIL3	HIGH PRESSURE SWITCH 2[HPS2_INPUT]	BOOL [24 VAC]
DIL4	LOW PRESSURE SWITCH 2 [LPS2_INPUT]	BOOL [24 VAC]
DIL5	COOL REQUEST 1 [Y_INPUT]	BOOL [24 VAC]
DIL6	COOL REQUEST 2 [Y2_INPUT]	BOOL [24 VAC]
DIL7	BLOWER REQUEST [G_INPUT]	BOOL [24 VAC]
DIL8	HEATER REQUEST [W2_INPUT]	BOOL [24 VAC]
Digital Output		
Name	Variable	Type
DOL1	HEATER CONTACTOR	BOOL [24 VAC]
DOL2	OUTDOOR MOTOR RELAY	BOOL [24 VAC]
DOL3	INDOOR MOTOR RELAY	BOOL [24 VAC]
DOL4	COMPRESSOR 1 CONTACTOR	BOOL [24 VAC]
DOL5	COMPRESSOR 1 STAGE 2	BOOL [24 VAC]
DOL6	COMPRESSOR 2 CONTACTOR	BOOL [24 VAC]
DOL7	COMPRESSOR 1 STAGE 2	BOOL [24 VAC]
DOL8	LOCK OUT RELAY	BOOL [24 VAC]

Appendix B: PLC Sequence of Operation

Equipment should go through a commissioning/start up sequence recommended by manufacturer to ensure safety and system reliability. This document is only valid if the system is used as intended.

This document defines the manner and method of control of the system. It will cover the following operations and protections.

0.0 – Fan Operation

- 0.1 – On Mode
- 0.2 – Auto Mode

1.0 - Cooling Operation

- 1.1 – Mechanical Cooling Only
- 1.2 – Economizer Operation
 - Economizer Enable Modes
 - Standard Economizer
 - Partial Economizer

2.0 – Heating

- 2.1 – Electric Heat

3.0 –Refrigeration Protection

- 3.1 – High Pressure Lockout
- 3.2 – Low Pressure Lockout
- 3.3 – Anti-Short Cycle Function
- 3.4 – Emergency Shutdown

4.0 – Dehumidification

- 4.1 – Electric Heat Dehumidification

5.0 – User Enabled Protection

- 5.1 – Emergency Shutdown
- 5.2 – Emergency Ventilation

Equipment, devices, and necessary system components are specified in the respective section.

Note:

1. All inputs on the Controller goes through a 5 second Time-On Delay to prevent nuisance request. Outputs go through a 5-10 second staggered Time On delay to prevent nuisance tripping of breaker due to the inrush associated with inductive loads.
2. Normal Operating Mode describes a mode in which there are no active faults which would interrupt the operation of the system.

0.0 - Fan Operation

0.1 - On-Mode

Indoor Blower Motor Runs continuously.

0.2 - Auto Mode

Indoor Blower Motor runs when there is a request for Cooling, Heating or Dehumidification and continues to run for 90 Seconds after the request is satisfied. When using the built-in thermostat, the indoor fan comes on 10F below the setpoint and continues to run until 90 seconds after the respective condition is satisfied. This function is only applicable with the Marvair designed sensor. Off-the-shelf thermostat operates based on a request for blower (G signal).

1.0 - Cooling Operation

1.1 – Mechanical Cooling Only

This section will describe the sequence of operation which takes place during Direct Expansion (DX) cooling with the OA dampers at their minimum position.

In normal operating mode, a request for “Stage 1 Cooling (Y-input)” via communication (BACnet or MODBUS), Digital Input or Onboard Thermostat, energizes the Indoor Blower Motor and Compressor 1 relay outputs on the PLC continuously. The controller also provides analog outputs (PWM or 0-10VDC Signal) associated to the Indoor Motor. In Stage 1 Cooling operation, the compressor and the indoor fan remains on continuously but the outdoor fan cycles based on head pressure. The Fan Cycle Control Switch (Low Ambient Control) closes at approximately 400 PSI to bring on the outdoor fan and reopens at approximately 290 PSI to turn the outdoor fan motor off. The described operations remain active until the Cooling Setpoint is satisfied (Stage 1 request drops out).

If the temperature continues to increase pass the defined setpoint [Cooling Setpoint + Cooling Differential], Stage 2 Cooling is energized. This energizes the Compressor 2 Output along with maintaining all previous outputs for Stage 1 Cooling. This output remains energized until the thermostat’s Cooling Setpoint is satisfied. Once the setpoint is satisfied, the Compressor and the Outdoor fan outputs are de-energized. The indoor fan continues to operate of 90 sec

Note: This process describes the functionality with both an "off-the-shelf" thermostat and built-in thermostat.

1.2 – Economizer Operation

In Economizer mode, there are multiple process variables that are monitored and used to trigger Economizer operation. The process variables that are monitored are Outdoor Air Temperature (OAT), Outdoor Air Dewpoint (OAD) and Outdoor Air Enthalpy (OAE). The desired economizer option for control can be selected from the display on the PLC or via BACnet. The available options are described below.

1. **DRY-BULB FUNCTIONALITY: (Default):** [TOAT < TEconomizer Setpoint] ENTHALPY AND DEWPOINT ARE DESREGARDED
2. **ENTHALPY FUNCTIONALITY:** [OAE < Enthalpy Calculate]
Uses [OAT + Humidity Setpoint] to calculate an enthalpy for operation.
3. **OA Dewpoint Lockout (Enable/Disable):** [OADewpoint < OADewpoint Lockout User Defined] and [TOAT < TEconomizer Setpoint]
Uses [OAT + Humidity Setpoint] to calculate the dewpoint for operation.

When there is a request for “Stage 1 Cooling” and the outdoor conditions are satisfactory (based on selected mode of operation), the HVAC unit functions as follows.

Standard Economizer

1. Using- On-Board Thermostat

If economizer enable setpoint is satisfied, the Economizer Damper modulates to maintain the Room Temperature. If Room Temperature increases “20F” above the Cooling Setpoint, the system energizes the first compressor. Once the compressor is energized, the OA dampers close to the minimum position. If the Room temperature continue to rise above the [Cooling Setpoint + Cooling Differential (User Defined)], the system then energizes the second compressor/ cooling stage if applicable. During this mode, supply air temperature will operate

between 55°F and 60°F. The cooling stages remain energized until the Cooling Setpoint is satisfied. Note that in this mode, the economizer and the compressor CANNOT operate simultaneously.

2. Using Off-the-shelf Thermostat

If economizer enable setpoint is satisfied, the Economizer Damper modulates to maintain the Room Temperature. During this mode, supply air temperature will operate between 55°F and 60°F. If the economizer process is not sufficient to meet the cooling requirement, the thermostat energizes the second stage output which forces the HVAC unit into full capacity. Once the compressor(s) are energized, the OA dampers close to the minimum position. The cooling stages remain energized until the Cooling Setpoint is satisfied. Note that in this mode, the economizer and the compressor CANNOT operate simultaneously.

Note: If the economizer enable setpoint is not satisfied, the economizer closes to its minimum position and mechanical cooling is used to cool the space.

2.0 – Heating

2.1 – Electric Heat

When there is a request for “Heating (W2)” via communication (BACNET or MODBUS), Digital Input or On-board Thermostat, the HVAC unit will run the Indoor Motor for 10 seconds prior to energizing the Heater Output. Once the Heater output is energized, the Heater comes “On” at full capacity (no staging). The Heater will remain “On” until the Heating setpoint is satisfied. Note that the heater and indoor motor are interlocked in software which means that only a heating request is required.

3.0 – Refrigeration Protection

3.1 – High Pressure Lockout

This condition describes the abnormal rise in Head Pressure pass the system acceptable limit of approximately 660 PSI (+/- 10 PSI). The fault will only be active when the High-Pressure Switch (Normally Closed) opens during a request for Cooling. The first time this fault condition occurs, the system cuts the compressor off WITHOUT locking out. Once the pressure normalizes (drops below 450 PSI), the system will resume operation if the cooling call still exist. If this fault occurs a second time on the same Cooling request, the system locks out. Lockouts can be monitored at lockout contacts in the system, via BACnet or MODBUS or on the display on the PLC. After this lockout condition is reached, the cooling call must be cycled or the system must be power cycled to clear the fault. The system will maintain the lockout until the problem is rectified.

3.2 – Low Pressure Lockout

This condition describes the abnormal fall in Suction Pressure below approximately 45 PSI (+/- 10 PSI). This fault will only be active when the Low-Pressure Switch (Normally Closed) opens during a request for Cooling. The Low-Pressure Switch is bypassed on the initial call for cooling for 3 minutes to allow low ambient start-up of the system. Once these 3 minutes have elapsed, if the switch is still open, the system cuts off the compressor. Once the pressure normalizes, the system will restart the cooling operation. If the fault occurs a second time on the same call for cooling, the system locks out. To clear the fault, the Cooling request must be cycled or the system must be power cycled. The system will continue to lockout unit the problem is rectified.

3.3 – Anti-Short Cycle

This is a built-in protection mechanism that increases the reliability of the compressor by protecting it from excessive short cycling. When the compressor goes off, due to any fault, emergency or if the cooling setpoint is satisfied, a built-in 3-minute timer locks the compressor out.

3.4– Emergency Shutdown

This condition is customer triggered. It can be done by opening the EMS-input on the PLC or triggered from BACnet. If this circuit is opened, all outputs are immediately terminated. That is, all dampers close completely and all motors immediately go off. If this input remains open, the system will not run. The display on the PLC provides the status of all inputs on the PLC.

4.0 – Dehumidification

4.1 – Electric Heat Dehumidification

Dehumidification mode needs to be Enabled on the PLC for this functionality to work. The Dehumidification mode has the lowest priority and will only be executed after the Cooling or Heating setpoints are met. Dehumidification request can also be triggered via BACnet. If the dehumidification functionality is enabled and the space humidity is greater than the dehumidification setpoint (User Defined), the HVAC unit will run the Indoor Motor, Stage 1 Compressor Only and the Electric Heat Simultaneously.

5.0 – User Enabled Protection

5.1 – Emergency Shutdown

This operation is customer triggered. It can be done by opening the EMS-input on the PLC or triggered from BACnet. If this circuit is opened, all outputs are immediately terminated. That is, all dampers close completely and all motors immediately go off. If this input remains open, the system will not run. The display on the PLC provides the status of all inputs on the PLC.

5.2 – Emergency Ventilation

This operation is customer triggered. When the respective input is set to the on-state, the HVAC controller terminates all air-conditioning processes and runs the indoor motor. If Emergency Ventilation and Emergency Shutdown are active simultaneously, Emergency ventilation takes priority. That is, the indoor motors would continue to operate while all air-conditioning operation is terminated.

Appendix C: PLC MODBUS Variables

Address	Name	Data Type	Default	Min	Max	Access Level	Description
8965	Y_MEM	Boolean	0			READ	MEMORY LOCATION FOR MONITORING COMPRESSOR 1 - STAGE 1 COOLING REQUEST (INPUT)
8966	Y2_MEM	Boolean	0			READ	MEMORY LOCATION FOR MONITORING COMPRESSOR 2 - STAGE 1 COOLING REQUEST (INPUT)
8967	G_MEM	Boolean	0			READ	MEMORY LOCATION FOR MONITORING INDOOR BLOWER REQUEST (INPUT)
8969	IBM_MEM	Boolean	0			READ	MEMORY LOCATION FOR MONITORING INDOOR BLOWER REQUEST (OUTPUT)
8970	OFM_MEM	Boolean	0			READ	MEMORY LOCATION FOR MONITORING OUTDOOR FAN REQUEST (OUTPUT)
8971	CC1_MEM	Boolean	0			READ	MEMORY LOCATION FOR MONITORING COMPRESSOR 1 - STAGE 1 COOLING REQUEST (OUTPUT)
8972	CC2_MEM	Boolean	0			READ	MEMORY LOCATION FOR MONITORING COMPRESSOR 2 - STAGE 2 COOLING REQUEST (OUTPUT)
8973	HEATER1_MEM	Boolean	0			READ	MEMORY LOCATION FOR MONITORING HEATING REQUEST (OUTPUT)
8977	LOI_MEM1	Boolean	0			READ	MEMORY LOCATION FOR MONITORING COMMON LOCKOUT ALARM (OUTPUT)
8978	LPS1_MEM	Boolean	0			READ	MEMORY LOCATION FOR MONITORING CIRCUIT 1 LOW PRESSURE SWITCH (INPUT)
8979	LPS2_MEM	Boolean	0			READ	MEMORY LOCATION FOR MONITORING CIRCUIT 2 LOW PRESSURE SWITCH (INPUT)
8980	HPS1_MEM	Boolean	0			READ	MEMORY LOCATION FOR MONITORING CIRCUIT 1 HIGH PRESSURE SWITCH (INPUT)
8981	HPS2_MEM	Boolean	0			READ	MEMORY LOCATION FOR MONITORING CIRCUIT 2 HIGH PRESSURE SWITCH (INPUT)
8982	EMS_MEM	Boolean	0			READ	MEMORY LOCATION FOR MONITORING EMERGENCY SHUTDOWN CONTACT (INPUT)
8983	SHORT_CYCLE_MEM	Boolean	0			READ	MEMORY LOCATION FOR MONITORING ANTI-SHORT CYCLE FOR COMPRESSOR CIRCUIT 1
8985	W2_MEM	Boolean	0			READ	MEMORY LOCATION FOR MONITORING HEATING REQUEST (OUTPUT)
8986	LOCKOUT_LPS1	Boolean	0			READ	MEMORY LOCATION FOR MONITORING CIRCUIT 1 LOW PRESSURE SWITCH LOCKOUT
8987	LOCKOUT_LPS2	Boolean	0			READ	MEMORY LOCATION FOR MONITORING CIRCUIT 2 LOW PRESSURE SWITCH LOCKOUT
8988	LOCKOUT_HPS1	Boolean	0			READ	MEMORY LOCATION FOR MONITORING CIRCUIT 1 HIGH PRESSURE SWITCH LOCKOUT
8989	LOCKOUT_HPS2	Boolean	0			READ	MEMORY LOCATION FOR MONITORING CIRCUIT 2 HIGH PRESSURE SWITCH LOCKOUT
8990	LOCKOUT_EMS	Boolean	0			READ	MEMORY LOCATION FOR MONITORING EMERGENCY SHUTDOWN LOCKOUT
8999	Y_MEM_STG2	Boolean	0			READ	MEMORY LOCATION FOR MONITORING COMPRESSOR 1 - STAGE 2 COOLING REQUEST (INPUT)
9000	Y2_MEM_STG2	Boolean	0			READ	MEMORY LOCATION FOR MONITORING COMPRESSOR 2 - STAGE 2 COOLING REQUEST (INPUT)
9001	CC1_STG2	Boolean	0			READ	MEMORY LOCATION FOR MONITORING COMPRESSOR 1 - STAGE 2 COOLING REQUEST (OUTPUT)
9002	CC2_STG2	Boolean	0			READ	MEMORY LOCATION FOR MONITORING COMPRESSOR 2 - STAGE 2 COOLING REQUEST (OUTPUT)

Address	Name	Data Type	Default	Min	Max	Access Level	Description
9003	IBM_OffDelay	Real	1			READ/WRITE	MEMORY LOCATION FOR SETTING INDOOR MOTOR TIME OFF DELAY
9005	ECON_HumSP	Real	0			READ/WRITE	MEMORY LOCATION FOR SETTING OUTDOOR HUMIDITY ENABLE (ONLY APPLICABLE IF LOCATION "9090" IS SET TO "0")
9007	ECON_MAS_scaled	Real	0			READ	MEMORY LOCATION FOR MONITORING THE MIX/SUPPLY AIR TEMPERATURE
9009	ECON_ORH_scaled	Real	0			READ	MEMORY LOCATION FOR MONITORING THE OUTDOOR AIR RELATIVE HUMIDITY
9011	ECON_STATUS	Boolean	0			READ	MEMORY LOCATION FOR MONITORING THE STATUS OF THE ECONOMIZER
9013	SHORT_CYCLE_MEM_2	Boolean	0			READ	MEMORY LOCATION FOR MONITORING ANTI-SHORT CYCLE FOR COMPRESSOR CIRCUIT 2
9016	Cool_SP	Real	0			READ/WRITE	MEMORY LOCATION FOR SETTING COOLING SETPOINT (APPLICABLE IF INTERNAL THERMOSTAT IS USED)
9019	Tstat_Mode	Signed 16-bit	0			READ/WRITE	0:OFF, 1:COOL, 2:HEAT, 3:AUTO (ONLY WORKS IF SENSOR IS INSTALLED IN UNITS)
9020	Tstat_Cool	Boolean	0			READ	MONITORS STATUS OF TSTAT MODE [IF EQUAL TO 1 - TSTAT MODE IS COOL ONLY]
9021	Tstat_Heat	Boolean	0			READ	MONITORS STATUS OF TSTAT MODE [IF EQUAL TO 1 - TSTAT MODE IS HEAT ONLY]
9022	Tstat_Auto	Boolean	0			READ	MONITORS STATUS OF TSTAT MODE [IF EQUAL TO 1 - TSTAT MODE IS COOL OR HEAT ONLY]
9023	Tstat_Off	Boolean	0			READ	MONITORS STATUS OF TSTAT MODE [IF EQUAL TO 1 - TSTAT MODE IS OFF]
9024	Heat_SP	Real	0			READ/WRITE	MEMORY LOCATION FOR SETTING HEATING SETPOINT (APPLICABLE IF INTERNAL THERMOSTAT IS USED)
9034	Cool_Dif	Signed 16-bit	0	2		READ	MEMORY LOCATION FOR SETTING COOLING DIFFERENTIAL (APPLICABLE IF INTERNAL THERMOSTAT IS USED)
9035	Heat_Dif	Signed 16-bit	0	2		READ	MEMORY LOCATION FOR SETTING HEATING DIFFERENTIAL (APPLICABLE IF INTERNAL THERMOSTAT IS USED)
9036	HUM_SP	Signed 16-bit	0			READ	MEMORY LOCATION FOR SETTING HUMIDITY SETPOINT (APPLICABLE IF INTERNAL THERMOSTAT IS USED)
9037	HUM_CTRL	Boolean	0			READ/WRITE	0 : DISABLES DEHUMIDIFICATION CONTROL , 1 : ENABLES DEHUMIDIFICATION CONTROL
9038	RemoteShutdown	Boolean	0			READ/WRITE	0 : ALLOWS NORMAL OPERATION , 1 : TRIGGERS EMERGENCY SHUTDOWN
9039	RoomHumScaled	Real	0			READ	MONITORS SPACE HUMIDITY
9041	RoomTempScaled	Real	0			READ	MONITORS SPACE TEMPERATURE
9045	Temp2Scaled	Real	0			READ	MONITORS OUTDOOR TEMPERATURE
9047	Temp2_Offset	Real	0			READ/WRITE	OFFSET VALUE FOR OUTDOOR TEMPERATURE
9049	SHORTCYCLETIME	Signed 16-bit	0			READ/WRITE	MEMORY LOCATION FOR SETTING ANTI-SHORT CYCLE TIME
9050	HumidityOffset	Signed 16-bit	0			READ/WRITE	OFFSET VALUE FOR SPACE HUMIDITY
9056	TStat_G_Op	Boolean	0			READ/WRITE	0: INDOOR FAN RUNS ON AUTO, 1: INDOOR FAN RUNS CONTINUOUSLY
9059	RoomTemp1_Offset	Real	0			READ/WRITE	ALLOWS USER TO CALIBRATE THE MEASURED ROOM TEMPERATURE

Address	Name	Data Type	Default	Min	Max	Access Level	Description
9063	BlowerSpeed	Signed 16-bit	0			READ/WRITE	MONITORS THE CURRENT SPEED OF INDOOR MOTOR. (VALUE SHOULD BE DIVIDED BY 10)
9064	OFMSpeed	Signed 16-bit	0			READ/WRITE	SET OPERATING SPEED OF THE INDOOR MOTOR
9065	HeadPressureCtrl	Boolean	0			READ/WRITE	0: OUTDOOR FAN RUNS AT "OFMSpeed" 1:OUTDOOR FAN RUNS MODULATES TO MAINTAIN LIQUID LINE TEMP OF 100 F
9066	OFM_ProportionalVal	Real	0			READ/WRITE	PROPORTIONAL VALUE FOR MODULATING THE OUTDOOR FAN MOTOR.
9068	OFM_IntegralVal	Real	0			READ/WRITE	INTEGRAL VALUE FOR MODULATING THE OUTDOOR FAN MOTOR.
9070	HeadPressureScaled1	Real	0			READ	MONITOR LIQUID LINE TEMPERATURE OF CIRCUIT 1
9072	HeadPressureOffset1	Real	0			READ/WRITE	ALLOWS USER TO CALIBRATE THE MEASURED LIQUID LINE TEMPERATURE OF CIRCUIT 1
9078	HeadPressureScaled2	Real	0			READ	MONITOR LIQUID LINE TEMPERATURE OF CIRCUIT 2
9080	HeadPressureOffset2	Real	0			READ/WRITE	ALLOWS USER TO CALIBRATE THE MEASURED LIQUID LINE TEMPERATURE OF CIRCUIT 2
9086	ECON_TempSP	Real	0			READ/WRITE	CHANGEOVER SETPOINT FOR THE ECONOMIZER
9088	ECON_OAT_scaled	Real	0			READ	ALLOWS USER TO CALIBRATE THE MEASURED OUTDOOR AIR TEMPERATURE
9092	CoolOption	Signed 16-bit	0			READ/WRITE	0 : DX COOLING ONLY 1 : ECONOMIZER
9093	OAH_Offset	Real	0			READ/WRITE	ALLOWS USER TO CALIBRATE THE MEASURED OUTDOOR AIR HUMIDITY
9095	MAT_Offset	Real	0			READ/WRITE	ALLOWS USER TO CALIBRATE THE MEASURED SUPPLY AIR TEMPERATURE
9097	EconDamper_HighLimit	Real				READ/WRITE	MAXIMUM ALLOWED POSITION FOR THE DAMPER
9099	EconDamper_LowLimit	Real	0		40	READ/WRITE	MINIMUM ALLOWED POSITION FOR THE DAMPER
9101	EconDamper_ManualCtrl	Boolean	0			READ/WRITE	0 : DAMPER MODULATES 1 : DAMPER OPENS TO THE POSITION "EconDamper_ManualVal". DURING ECONOMIZING
9102	EconDamper_ManualVal	Real	0			READ/WRITE	POSITION THE DAMPER OPENS TO DURING ECONOMIZING
9104	EconDamper_ActualPos	Real	0			READ	POSITION THE CONTROLLER IS REQUESTING THE DAMPER TO OPEN UP TO
9106	UnitNum	Signed 16-bit	1	1		READ/WRITE	BACNET ID
9116	Stg1_Speed	Signed 16-bit	50			READ/WRITE	INDOOR MOTOR COOL SPEED - STAGE 1
9117	Stg2_Speed	Signed 16-bit	55			READ/WRITE	INDOOR MOTOR COOL SPEED - STAGE 2
9118	Stg3_Speed	Signed 16-bit	60			READ/WRITE	INDOOR MOTOR COOL SPEED - STAGE 3
9119	Stg4_Speed	Signed 16-bit	60			READ/WRITE	INDOOR MOTOR COOL SPEED - STAGE 4
9120	Stg5_Speed	Signed 16-bit	65			READ/WRITE	INDOOR MOTOR COOL SPEED - STAGE 5
9121	G_Speed	Signed 16-bit	50			READ/WRITE	FAN ONLY SPEED
9122	W2_Speed	Signed 16-bit	65			READ/WRITE	INDOOR MOTOR - HEATER SPEED
9135	DirtyFilter_Warning	Boolean	0			READ	
9176	EconForceClose	Boolean	0			READ/WRITE	ALLOWS USER TO FORCE ECONOMIZER CLOSE. 0 : OFF 1 : CLOSE DAMPER
9180	SystemCapacityOp	Signed 16-bit	0			READ/WRITE	0:Full Capacity; 1:Staged Capacity ; 2: Dual Compressor Op

Appendix D: PLC BACNET Analog Variables

PARAMETER Name	Description	Units	Access
BAV1_T-StatMode	0:OFF, 1:COOL, 2:HEAT, 3:AUTO	Binary	Read/Write
BAV3_CoolSetpoint	Cooling Setpoint	Temp (F)	Read/Write
BAV4_HeatSetpoint	HeatingSetpoint	Temp (F)	Read/Write
BAV5_HumiditySetpoint	Humidity Setpoint	RH (%)	Read/Write
BAV6_RoomTemp	Average Temperature Used To Control Unit	Temp (F)	ReadOnly
BAV7_RoomHumidity	Average Humidity Used To Control Unit	RH (%)	ReadOnly
BAV10_OutdoorAirTemp	Measured Outdoor Air Temperature	Temp (F)	Read Only
BAV11_OutdoorAirTempOffset	Offset value for calibrating Outdoor Air Temperature measurement	Temp (F)	Read/Write
BAV12_IndoorBlowerSpeed	Monitors the speed at which the indoor motor is being requested to operate at	(%)	Read Only
BAV13_OutdoorBlowerSpeed	Speed setting at which the outdoor motor will operate when requested	(%)	Read/Write
BAV14_CoolOption	0:Mechanical Cooling Only, 1: Economizer OR Mechanical Cooling , 2:Economizer AND Mechanical Cooling	N/A	Read/Write
BAV15_EconomizerTempSP	Temperature below which the economizer initiates on an active cooling request	Temp (F)	Read/Write
BAV16_EconomizerHumSP	Humidity at which the economizer initiates on cooling request. Only Applicable is "BAV14_CoolOption" and "BAV58_EconomizerSensorSelection" are not equal to 0	(%)	Read/Write
BAV17_EconomizerDamperMinimumPos	Minimum position of the economizer damper	Open (%)	Read/Write
BAV18_EconomizerDamperMaximumPos	Maximum position of the economizer damper	Open (%)	ReadOnly
BAV19_HeadPressure1	Monitors the Liquid Line Temperature of Circuit 1	Temp (F)	Read Only
BAV20_SuctionPressure1	Monitors the Suction Line Temperature of Circuit 1	Temp (F)	Read Only
BAV21_HeadPressure2	Monitors the Liquid Line Temperature of Circuit 2	Temp (F)	Read Only
BAV22_SuctionPressure2	Monitors the Suction Line Temperature of Circuit 1	Temp (F)	Read Only
BAV23_CoolStg1Speed	Indoor Blower Speed setpoint for Cool Stage 1	(%)	Read/Write
BAV24_CoolStg2Speed	Indoor Blower Speed setpoint for Cool Stage 2 (Stage 1 Cooling in 2 Stage Operation)	(%)	Read/Write
BAV25_CoolStg3Speed	Indoor Blower Speed setpoint for Cool Stage 3	(%)	Read/Write
BAV26_CoolStg4Speed	Indoor Blower Speed setpoint for Cool Stage 4	(%)	Read/Write
BAV27_CoolStg5Speed	Indoor Blower Speed setpoint for Cool Stage 5 (Stage 2 Cooling in 2 Stage Operation)	(%)	Read/Write
BAV28_HeatStg1Speed	Indoor Blower Speed setpoint for Heating operation	(%)	Read/Write
BAV29_BlowerOnlySpeed	Indoor Blower Speed setpoint for fan only operation	(%)	Read/Write
BAV30_EconomizerPosition	Economizer Damper Position	Open (%)	ReadOnly
BAV31_EconomizerManualValue	Economizer manual value. Only applicable when economizer is in manual mode (BBV31=1)	Open (%)	Read/Write
BAV32_CustomerTemp1	(Not Part of Standard Offering) Measure value for Temperature Sensor 1	Temp (F)	ReadOnly
BAV33_CustomerTemp2	(Not Part of Standard Offering) Measure value for Temperature Sensor 2	Temp (F)	ReadOnly
BAV34_CustomerTemp3	(Not Part of Standard Offering) Measure value for Temperature Sensor 3	Temp (F)	ReadOnly
BAV35_CustomerTemp4	(Not Part of Standard Offering) Measure value for Temperature Sensor 4	Temp (F)	ReadOnly

PARAMETER Name	Description	Units	Access
BAV36_CustomerTemp5	(Not Part of Standard Offering) Measure value for Temperature Sensor 5	Temp (F)	ReadOnly
BAV68_CustomerTemp6	(Not Part of Standard Offering) Measure value for Temperature Sensor 6	Temp (F)	ReadOnly
BAV32_CustomerTemp1	Qty of Humidity Sensors Used in Averaging Control	Temp (F)	Read/Write
BAV42_CustomerHum1	(Not Part of Standard Offering) Measure value for Humidity Sensor 1	RH (%)	ReadOnly
BAV43_CustomerHum2	(Not Part of Standard Offering) Measure value for Humidity Sensor 2	RH (%)	ReadOnly
BAV44_CustomerHum3	(Not Part of Standard Offering) Measure value for Humidity Sensor 3	RH (%)	ReadOnly
BAV45_CustomerHum4	(Not Part of Standard Offering) Measure value for Humidity Sensor 4	RH (%)	ReadOnly
BAV46_CustomerHum5	(Not Part of Standard Offering) Measure value for Humidity Sensor 5	RH (%)	ReadOnly
BAV69_CustomerHum6	(Not Part of Standard Offering) Measure value for Humidity Sensor 6	RH (%)	ReadOnly
BAV52_MixedAirSensorValue	Measured Value of the Mixed Air Sensor	Temp (F)	ReadOnly
BAV54_SupplyAirSensorValue	Measured Value of the Supply Air Sensor (Standard Design uses the "BAV54" for both supply and mixed measurement)	Temp (F)	ReadOnly
BAV55_SupplyAirTempOffset	Offset value to calibrate the value measured by the Supply Air Temperature Sensor	Temp (F)	Read/Write
BAV56_MixedAirTempOffset	Offset value to calibrate the value measured by the Mixed Air Temperature Sensor	Temp (F)	Read/Write
BAV57_OutdoorAirHumidityOffset	Offset value to calibrate the value measured by the Outdoor Humidity Sensor	RH (%)	Read/Write
BAV58_EconomizerSensorSelection	0 : Drybulb, 1: Enthalpy + Drybulb , 2: Dewpoint + Drybulb	Binary	Read/Write
BAV59_EconomizerTempDif	Deadband offset value for Economizer Temperature process variable as it relates to the Space Temperature	Temp (F)	Read/Write
BAV60_EconomizerEnthalpyDif	Deadband offset value for Economizer Enthalpy process variable as it relates to the Space Enthalpy	(BTU/lb-air)	Read/Write
BAV61_EconomizerDewpointSetpoint	Economizer Dewpoint Lockout Setpoint	Temp (F)	Read/Write
BAV63_SpaceEnthalpy	Measured Enthalpy of Space	(BTU/lb-air)	Read Only
BAV65_OutdoorEnthalpy	Measured Outdoor Enthalpy	(BTU/lb-air)	Read Only
BAV66_OutdoorDewpoint	Measured Outdoor Dewpoint	Dewpoint (F)	Read Only
BAV67_OutdoorHumidity	Measured Outdoor Humidity	RH (%)	Read Only
BAV74_RevisionLevel	Revision Level of the PLC software	N/A	Read Only

Appendix E: PLC BACNET Binary Variables

PARAMETER Name	Description	Units	Access
BBV0_HPS1_R	Monitor Circuit 1 High Pressure Input. 0:Fault, 1:OK	Binary	ReadOnly
BBV1_LPS1_R	Monitor Circuit 1 Low Pressure Input. 0:Fault, 1:OK	Binary	ReadOnly
BBV2_HPS2_R	Monitor Circuit 2 High Pressure Input. 0:Fault, 1:OK (Only Applicable on Dual Compressor Unit)	Binary	ReadOnly
BBV3_LPS2_R	Monitor Circuit 2 Low Pressure Input. 0:Fault, 1:OK (Only Applicable on Dual Compressor Unit)	Binary	ReadOnly
BBV4_EMS_R	Monitor Emergency Shutdown Input. 0:Fault, 1:OK	Binary	ReadOnly
BBV5_Cooling1_R	Monitor Compressor Circuit 1 Request. 1:ON, 0:OFF	Binary	ReadOnly
BBV6_Cooling2_R	Monitor Compressor Circuit 2 Request. 1:ON, 0:OFF (Only Dual Compressor Unit)	Binary	ReadOnly
BBV7_IndoorFan_R	Monitor Request for the Indoor Blower Motor. 1:ON, 0:OFF (Verifies if there is a call for the blower to be on)	Binary	ReadOnly
BBV10_RemoteShutdown_RW	Allow end user to Remote Shutdown the HVAC Unit. 1:Active, 0:Inactive (Emergency Shutdown)	Binary	Read/Write
BBV11_CoolReqStg1_RW	Variable for Requesting first stage cooling (Y signal). 1:Request, 0: No Request	Binary	Read/Write
BBV12_CoolReqStg2_RW	Variable for Requesting second stage cooling (Y2 signal). 1:Request, 0: No Request	Binary	Read/Write
BBV13_HeatReqStg1_RW	Variable for Requesting first stage heating (W1 signal). 1:Request, 0: No Request	Binary	Read/Write
BBV15_IndoorFanReq_RW	Variable for Requesting Fan Only. 1:Request, 0: No Request	Binary	Read/Write
BBV17_BlowerSetting_RW	Indoor Blower Control Setup. 0:Auto , 1:ON Mode. In auto Mode, the fan cycles when running. In "On" mode the fan runs continuously.	Binary	Read/Write
BBV20_EconomizerDamperControl_RW	Variable for controlling the Economizer Damper Manually or have it automatically controlled. In Manual Mode, opening position is set by end user (BAV31_EconomizerManualValue). 0:Automatic Mode, 1: Manual Mode. Note that the dampers will only open when there is a request for economizer.	Binary	Read/Write
BBV22_DirtyFilter_R	Variable for monitoring the status of the Dirty Filter switch. 1:OK, 0:Dirty	Binary	ReadOnly
BBV23_EconDamperForceClose	Variable for forcing damper close. 1: Close OA Damper, 0: Normal Operation (Emergency OA Shutdown)	Binary	Read/Write
BBV24_EconDamperForceOpen	Variable for forcing damper into manual control. This will force damper to position set by end user at variable "BAV31_EconomizerManualValue". Note that this is does not depend on an active request for economizer.	Binary	Read/Write
BBV25_HumidityCtrlEnable	Dehumidification Functionality Enable/Disable. 1:ENABLE, 0:DISABLE	Binary	Read/Write

Appendix F: Fresh Air Damper Installation

HOW TO INSTALL FRESH AIR DAMPER ASSY(88):

- DETACH ITEM 50 - COVER PLATE FROM ITEM 7 - MAIN UNIT AND DISCARD
- ATTACH ITEM 88 - DAMPER ASSY TO ITEM 7 - MAIN UNIT

HOW TO REPLACE FILTER(91):

- DETACH ITEM 90 - FILTER COVER FROM ITEM 88 - DAMPER ASSY
- SLIDE ITEM 91 - FILTER OUT/IN
- ATTACH ITEM 90 - FILTER COVER TO ITEM 88 - DAMPER ASSY

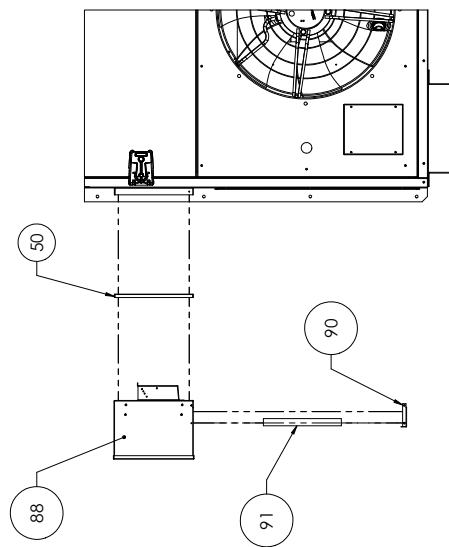
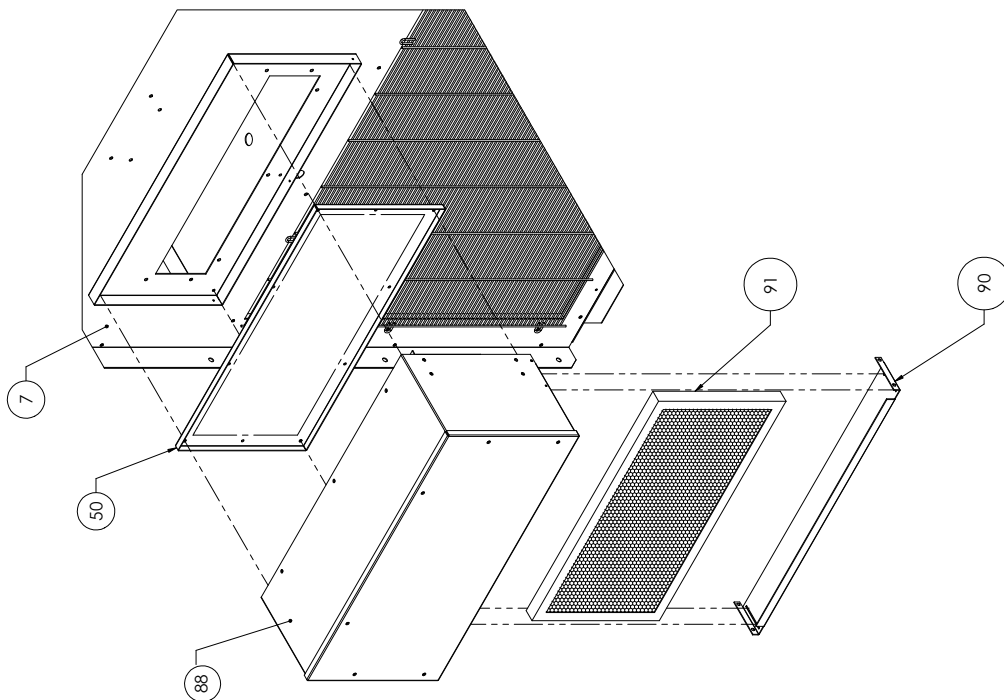

Fresh Air Hood Adjustment (non-economizer air conditioners only)

The fresh air hood is located on the inside, behind the slots on the bottom front panel. To access the hood, remove the screws that hold the front panel. The air flow can be adjusted from no (0%) fresh air to approximately 15% of rated air flow of fresh air, in 5% increments. The hood is shipped from the factory in the closed position (no fresh air). To provide fresh air, remove the two screws on either side of the hood and reposition as desired.

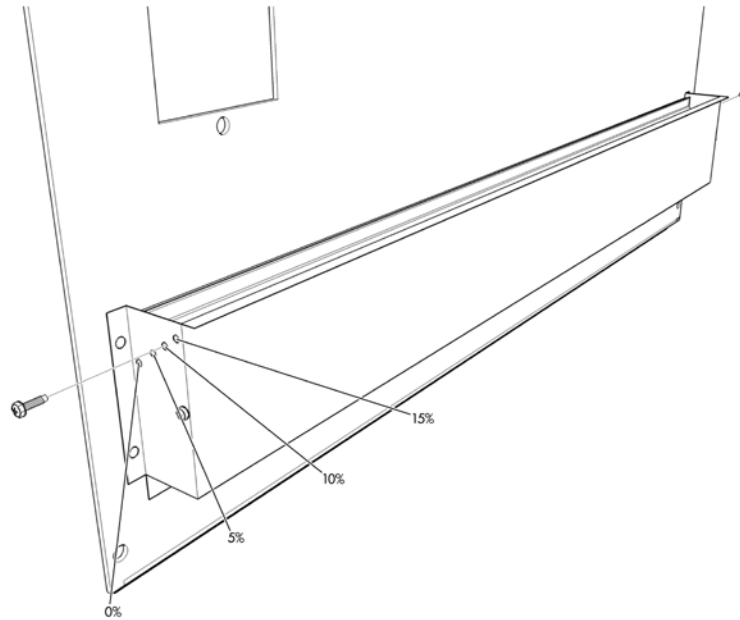

Fresh Air Hood Damper

Appendix G

CFA3240A Center Supply/Top Return w/Economizer Exhaust Hood Installation

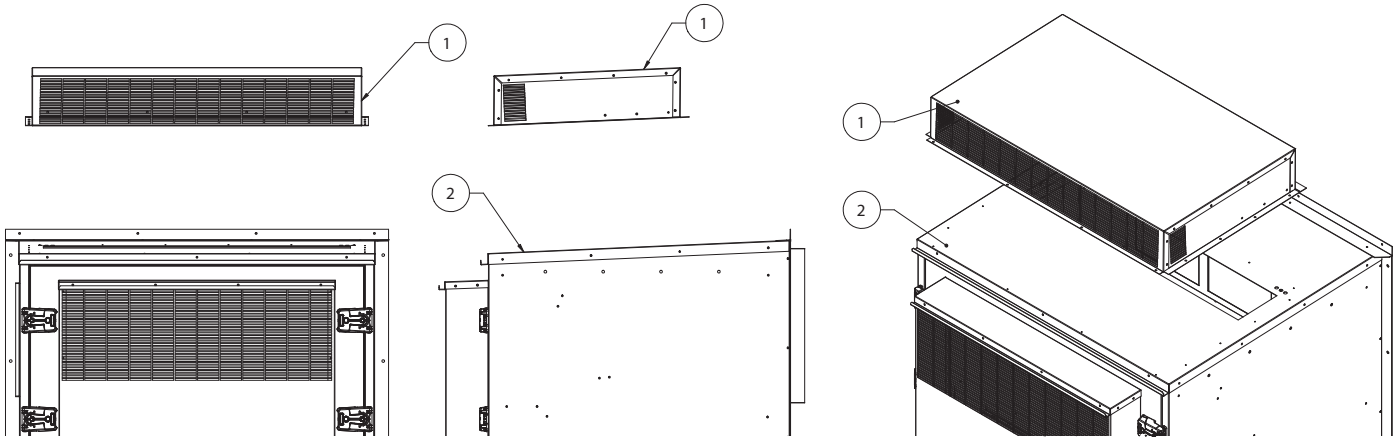

- A. MAKE SURE FACTORY SUPPLIED GASKET IS PROPERLY ATTACHED TO THE BOTTOM FLANGES OF THE HOOD ASSY (ITEM 1)
- B. PLACE HOOD ASSY (ITEM 1) ON TOP OF UNIT WITH SLOTTED VENTS TOWARDS THE FRONT OF THE UNIT
- C. ALIGN HOLES IN THE HOOD ASSY FLANGES WITH PREDRILLED HOLES IN THE TOP PANEL OF UNIT (ITEM 2)
- D. SCREW INTO PLACE WITH SHEET METAL SCREWS PROVIDED
- E. ADD SILICONE BEAD AROUND THE TWO SIDES AND REAR OF THE HOOD ASSY

Appendix H

Optional Condenser Filter Installation

- STEP 1-REMOVE COIL GUARD SAVE SCREWS FOR MOUNTING FILTER ASSY
- STEP 2-SCREW FRAME SIDES AND BOTTOM IN COIL GUARD MOUNTING HOLES
- STEP 3-SLIDE FILTER INTO FRAME
- STEP 4- SCREW FRAME TOP INTO COIL GUARD MOUNTING HOLES
- STEP 5-REPEAT 1-4 FOR OTHER SIDE PANEL

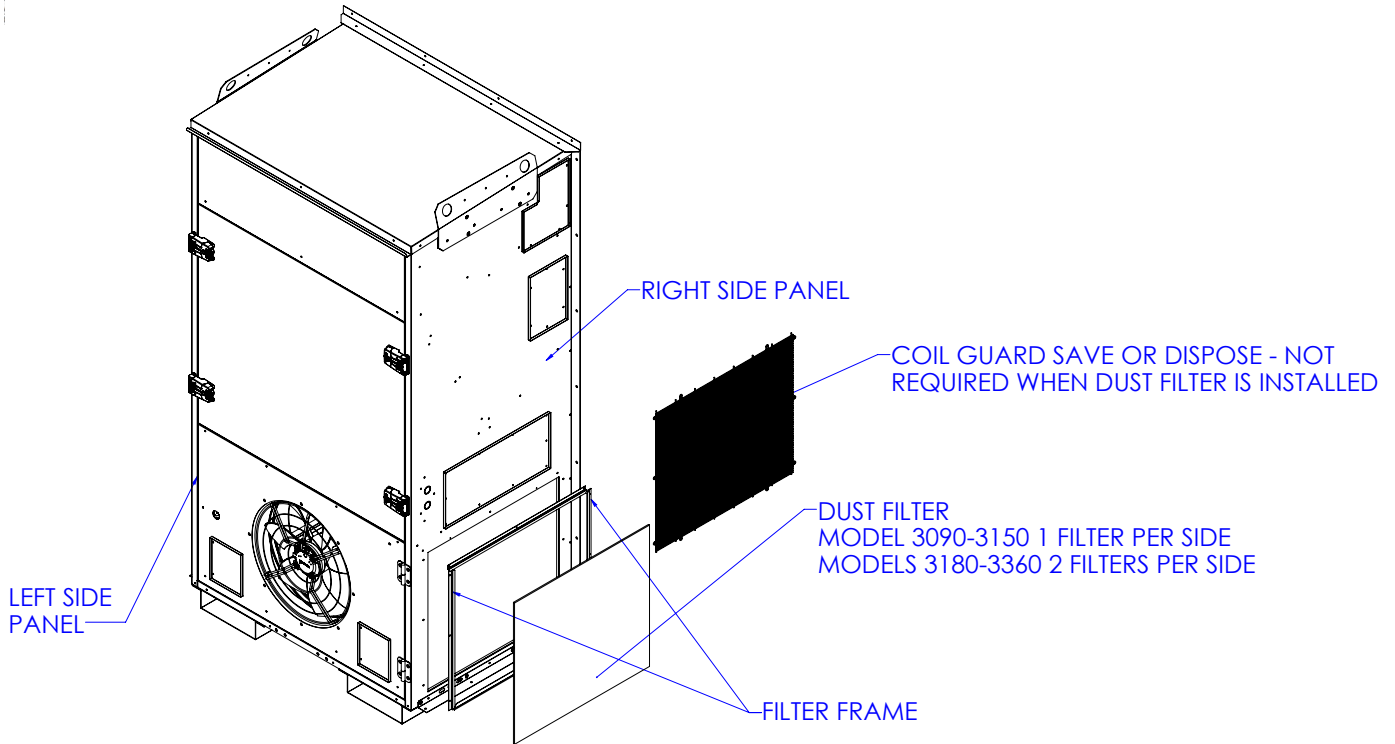

S/12908**		EXTERNAL CONDENSER FILTER ASSY 300-360	
	SML17015	EXTERNAL COND COIL SIDE MGA 300-360	4
	SML17016	EXTERNAL COND COIL BOT MGA 300-360	2
	SML17017	EXTERNAL COND COIL TOP MGA 300-360	2
	93288	FILTER CONDENSER 300-360 64.75X36.625	4
S/12907**		EXTERNAL CONDENSER FILTER ASSY 180-240	
	SML17013	EXTERNAL COND COIL SIDE MGA 180-240	4
	SML17014	EXTERNAL COND COIL BOT MGA 180-240	2
	SML17018	EXTERNAL COND COIL TOP MGA 180-240	2
	93287	FILTER CONDENSER 180-240 44.875X36.5	4
S/12906**		EXTERNAL CONDENSER FILTER ASSY 120-+150	
	SML17009X	EXTERNAL COND COIL SIDE 1 MGA 90-150	2
	SML17010	EXTERNAL COND COIL SIDE 2 MGA 90-150	2
	SML17012	EXTERNAL COND COIL BOT MGA 120-150	2
	SML17019	EXTERNAL COND COIL TOP MGA 120-150	2
	93286	FILTER CONDENSER 120-150 36.875X28	2
S/12905**		EXTERNAL CONDENSER FILTER ASSY 90	
	SML17009X	EXTERNAL COND COIL SIDE 1 MGA 90-150	2
	SML17010	EXTERNAL COND COIL SIDE 2 MGA 90-150	2
	SML17011	EXTERNAL COND COIL BOT MGA 90	2
	SML17020	EXTERNAL COND COIL TOP MGA 90	2
	93285	FILTER CONDENSER 120-150 30.875X28	2

Appendix A

Appendix I

DPC200 Differential Pressure Controller



Installation and operation manual

DPC200 - DIFFERENTIAL PRESSURE CONTROLLER

Low pressure with PI-control-mode



Doc.-no.: DPC200_01_EBM_UK

Issue: 12/2015

Manufacturer: Arthur Grillo GmbH
Am Sandbach 7
40878 Ratingen

Phone: +49 21 02 - 47 10 22
Fax: +49 21 02 - 47 58 82
E-Mail: info@grillo-messgeraete.de
Website: www.grillo-messgeraete.de
www.sensor-store.de

Issue: 12/2015
Doc.-no.: DPC200_001_EBM_UK

This documentation including all parts is protected by copyright. Any utilisation or modification other than permissible under the strict limitations of copyright law is prohibited and liable to prosecution without the approval of the Arthur Grillo GmbH. This applies in particular to duplications, translations, microfilming and storage and processing in electronic systems.

Table of content

I	General safety instructions	04
	1.1 Signal words for safety instructions	04
	1.2 Used pictograms and symbols	04
	1.3 General notes	04
2	Product description	05
	2.1 Type plate	05
	2.2 Intended use	05
	2.3 Functional description	05
3	Installation	06
	3.1 Dimensions	06
	3.2 Wall mounting	06
4	Start up	07
	4.1 Overview DPC200	07
	4.2 Schematic view inside	07
	4.3 Pressure connections	07
	4.4 Electrical connection	08
	4.5 Zero adjustment	08
5	Operation	08
	5.1 Start menu	08
	5.2 Menu structure	09
	5.3 Measuring mode	10
	5.4 Control mode	11
	5.5 Adjustable parameters	12
	5.6 Function alarm output	13
6	Maintenance	13
7	Warranty	14
8	Troubleshooting	14
9	Disposal	14
10	Specifications	15
	10.1 CE-labelling	16
11	Ordering information	16

I. General safety instructions

I.1 Signal words for safety instructions

The safety instructions in this operation manual are designed to prevent hazards. They can be found in the operation manual before an operation / task / activity is described, which can entail a possible hazard.



CAUTION	Identification of a hazard with a low risk, which can lead to material damage or minor or moderate bodily injuries.
----------------	---

NOTICE	Signal word for important information regarding the product, which needs to be specifically pointed out.
---------------	--

Hazard word	Type of hazard
	Hazard source Hazard prevention

I.2 Used pictograms and symbols

In this manual the following symbols are used:

	General hazard symbol (danger, warning, caution)		General information
---	--	---	---------------------

I.3 General notes

NOTICE	This manual contains information for installation and operation of the pressure controller and is exclusively for the operator and expert staff. The guidelines in this manual will help to avoid danger and downtime.
	

2. Product description

The differential pressure controller DPC200 measures low pressure of inert gases, particularly of air.

2.1 Type plate

1. Product name
2. Measuring range
3. Supply voltage
4. Signal output
5. Serial no.
6. Manufacturer

pressure controller	1.	DPC200-EP500
measurement range:	500 Pa	2.
supply voltage:	3. $U_s (1+ 2-) = 10 \dots 30 \text{ Vdc} / 24 \text{ Vac}$	
signal output:	4. $U_{out} (3+ 4-) = 0 \dots 10 \text{ V}$	
part-no.: 2572	5. serial-no.: 15. 4700	
Arthur Grillo GmbH • Ratingen	6.	Made in Germany

2.2 Intended use

This device is primarily intended for use with air conditioning systems, room pressure control or filter control with ebm-papst continuously variable speed fans. It can be operated solely as a sensor (measuring mode) or closed loop controller for pressure / volumetric flow rate control. As analogue output the operator can use a signal from 0 ...10V DC. Depending on the settings the signal has different meanings:

1. If the device is used as a pressure sensor, the output signal is proportional to the measured pressure.
2. As a volume flow sensor the device outputs a square root signal.
3. With closed loop pressure or volume flow the output signal stands for the control variable of the PI-control.

2.3 Functional description

A soft silicone diaphragm is used as sensor. Under the influence of the differential pressure the diaphragm displaces a measuring spring until the spring force compensates for the pressure pushing on the diaphragm. A contactless differential transformer and suitable electronics convert this displacement into a continuously variable output voltage signal.

The DPC200 provides two function options:

1. On the one hand it is used as a measuring device. In the measuring mode the differential pressure is shown on the display, and a proportional 0...10V DC output signal is provided.
2. Besides the measuring mode the DPC200 also can be operated in a control mode. Two setpoints can be adjusted in the device and can be selected with the potential free contact input. The PI-Algorithm matches the measured differential pressure with the setpoint and operates the control variable so that a constant pressure results. The control variable is given as a 0...10V DC output signal.

Instead of the quantity 'differential pressure' also the quantity 'volume flow' can be used for measuring and for control.

3. Installation

The differential pressure controller DPC200 is designed for wall mounting.

- The mounting surface must be solid enough and vibration-free.
- The environment has to fulfil the ambient climatic conditions as given in the technical data.

	<p>CAUTION Material damage</p> <p>Read the manual carefully before installation and operation Only experienced staff may connect the device and bring it into operation.</p>
---	--

	<p>NOTICE</p> <ul style="list-style-type: none"> • The device is position depended. • The DPC200 must be mounted vertically.
---	---

3.1 Dimensions

All dimensions in mm.

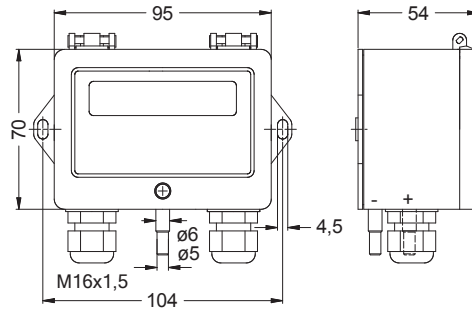

3.2 Wall mounting

1. Hold the DPC200 against the wall. Mark the mounting holes.
2. Drill mounting holes for properly sized screws.
3. Put the screws through the housing mounting holes.
4. Tighten screws.

4. Start up

4.1 Overview DPC200

1. Front cover
2. Cable gland
3. Pressure connection 1
4. Pressure connection 2
5. Cable gland

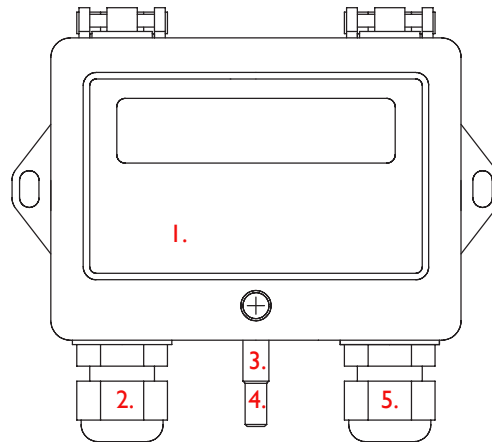

4.2 Schematic view inside

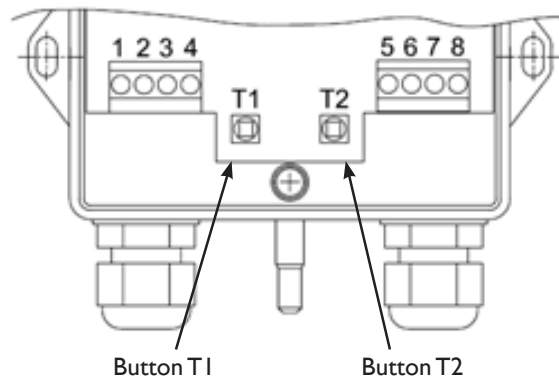

Button T1 and T2 serve for the operation of the menu

4.3 Pressure connections

Connect all pressure connections properly with plastic tubing (inner diameter 5 or 6mm).

4.4 Electrical connection

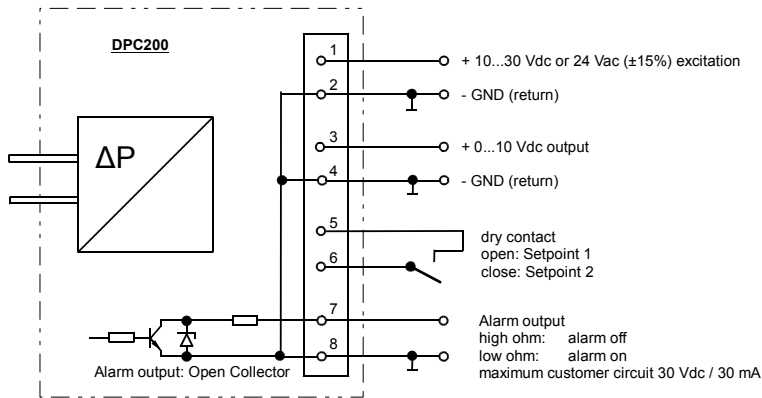

1. Unscrew screws of the front cover.
2. Open front cover.
3. Use M16 cable glands for connecting wiring to terminals.

4.5 Zero adjustment

The output signal offset can be zeroed from the outside with a small bar magnet. Do not use buttons T1 or T2.

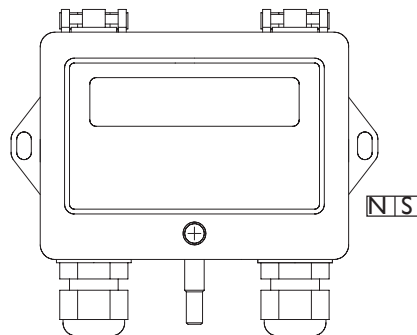

Adjustment:

- Remove the tubing from the pressure connections.
- Hold the bar magnet (N/S) as shown here to the zero point adjustment for a short period of time to activate an internal reed switch.

The new zero point will be displayed and stored.

5. Operation

5.1 Start menu

For operating the menu, unscrew the front cover to reach buttons T1 and T2.

5.2 Menu structure

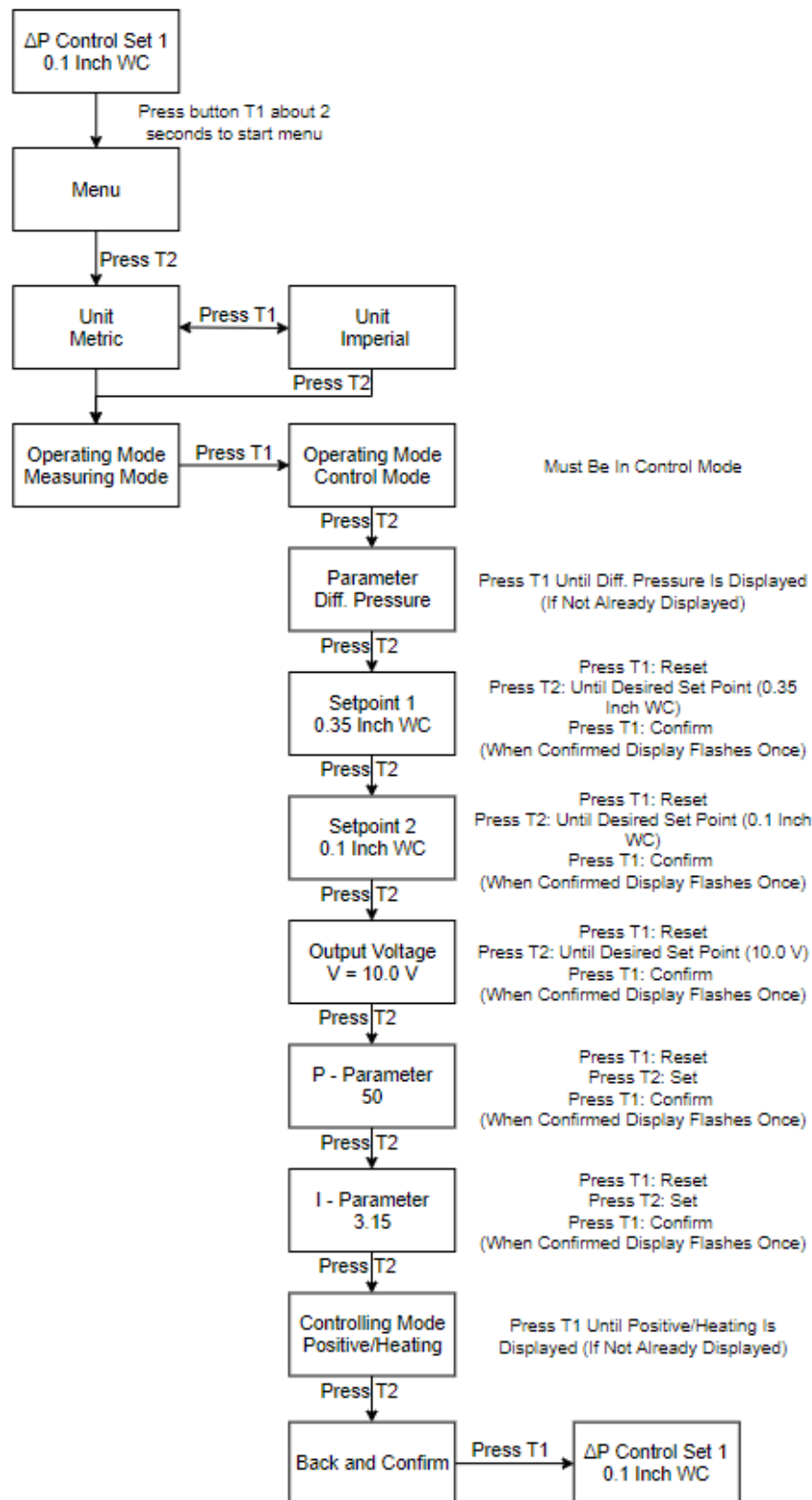

5.3 Measuring mode

Display	Action
ΔP Measurement 200 Pa	Start menu: Press button T1 approx. two seconds
menu	Press button T2 to get to the next menu item
unit metric	Press button T1 to switch between: metric <=> imperial Press button T2 to get to the next menu item
operating mode control mode	Press button T1 to switch between: measuring mode <=> control mode Press button T2 to get to the next menu item
parameter diff. pressure	Press button T1 to switch between: diff. pressure <=> volume flow Press button T2 to get to the next menu item

If selected parameter = diff. pressure	
limit switch 150 Pa	Button T1: reset value Button T2: set value Button T1: confirm value, display flashes once Press button T2 to get to the next menu item
back and confirm	Press button T1 to leave the menu Press button T2 to stay in the menu

If selected parameter = volume flow than follows the additional input for the k-factor	
fan k-factor k = 70	Button T1: reset value Button T2: set value Button T1: confirm value, display flashes once Press button T2 to get to the next menu item
limit switch 300 m³/h	Button T1: reset value Button T2: set value Button T1: confirm value, display flashes once Press button T2 to get to the next menu item
back and confirm	Press button T1 to leave the menu Press button T2 to stay in the menu

5.4 Control mode

Display	Action
ΔP Measurement 200 Pa	Start menu: Press button T1 approx. two seconds
menu	Press button T2 to get to the next menu item
unit metric	Press button T1 to switch between: metric <=> imperial Press button T2 to get to the next menu item
operating mode control mode	Press button T1 to switch between: measuring mode <=> control mode Press button T2 to get to the next menu item
parameter diff. pressure	Press button T1 to switch between: diff. pressure <=> volume flow Press button T2 to get to the next menu item
If selected parameter = diff. pressure resp. after the input of the k-factor follows:	
setpoint 1 50 Pa	Button T1: reset value Button T2: set value Button T1: confirm value, display flashes once Press button T2 to get to the next menu item
setpoint 2 250 Pa	Button T1: reset value Button T2: set value Button T1: confirm value, display flashes once Press button T2 to get to the next menu item
output voltage U = 10,0V DC	Button T1: reset value Button T2: set value Button T1: confirm value, display flashes once Press button T2 to get to the next menu item
P - parameter 50	Button T1: reset value Button T2: set value Button T1: confirm value, display flashes once Press button T2 to get to the next menu item
I - parameter 3,15	Button T1: reset value Button T2: set value Button T1: confirm value, display flashes once Press button T2 to get to the next menu item
controlling mode positive / heating	Press button T1 to switch between: positive / heating <=> negative / cooling Press button T2 to go to the next menu
back and confirm	Press button T1 to leave the menu Press button T2 to stay in the menu

If selected parameter = volume flow than follows the additional input for the k-factor	
fan k-factor k = 70	Button T1: reset value Button T2: set value Button T1: confirm value, display flashes once Press button T2 to get to the next menu item

5.5 Adjustable parameters

Parameter	Selection or parameter range	Default setting
Unit	Metric or imperial	metric
Operating mode:	Measuring mode or control mode	measuring mode
Parameter	Differential pressure ΔP [Pa or InH ₂ O] Volume flow V [m ³ /h or cfm]	differential pressure ΔP [Pa]
K-factor:	Volume flow calculation according to: $V = k \cdot \sqrt{\Delta p}$ with: V = Volume flow in m ³ /h or cfm k = flow factor; adjustment range: 1...1000 measuring range up to 4000 Pa Δp = differential pressure in Pa or InH ₂ O Volume flow calculation up to 65,500 m ³ /h (38,514 cfm) In measuring or control mode Maximum volume flow (V_{max}) Measuring range: 50 Pa, k=1000 $\rightarrow V_{max} = 7,071$ m ³ /h; (4,157 cfm) Measuring range: 500 Pa, k=1000 $\rightarrow V_{max} = 22,360$ m ³ /h; (13,147 cfm) Measuring range: 1000 Pa, k=1000 $\rightarrow V_{max} = 31,622$ m ³ /h; (18,593 cfm) Measuring range: 2000 Pa, k=1000 $\rightarrow V_{max} = 44,721$ m ³ /h; (26,295 cfm) Measuring range: 4000 Pa, k=1000 $\rightarrow V_{max} = 63,245$ m ³ /h; (37,188 cfm)	K = 70
Limit values:	Differential pressure from 0 % up to 100 % of measuring range. Volume flow from 5 % up to 100 % of measuring range, k-factor is considered.	OFF
Nominal values (setpoints):	Differential pressure from 0 % up to 100 % of measuring range. Volume flow from 5 % up to 100 % of measuring range, k-factor is considered.	Set 1: 75 % Set 2: 25 %
Output voltage:	0...10V DC	$U_{out} = 10V$ DC
P-gain:	0...1000	P = 50
I-gain:	0...100	I = 3.15
Control characteristic:	positive/(heating): Control deviation = set value – actual value The output increases when set value > actual value. negative/(cooling): Control deviation = actual value – set value The output increases when actual value > set value	positive / heating

5.6 Function alarm output

The DPC200 has an open collector alarm output; depending on the operating mode the function is different.

At the **alarm event** a contact between terminal no. 7 and no. 8 gets low-resistive and can be loaded with a maximum of 30 V DC/ 30 mA. When the alarm is switched off the contact will be high-resistive.

During alarm state in the control mode / measuring mode an exclamation point is displayed (2nd line / 16th character).

Control mode:

In order to recognize the limits of control, the alarm output in the control mode refers to the set maximum output voltage (MaxU_{out}). MaxU_{out} can be set in the menu item „output voltage“.

In the default setting the value is set to 10V DC.

Alarm ON: Output voltage for 12 seconds constantly greater than: $0.95 \cdot \text{MaxU}_{\text{out}}$

Alarm OFF: Output voltage for 12 seconds constantly less than: $0.9 \cdot \text{MaxU}_{\text{out}}$

Measuring mode:

For limit value monitoring a limit value can be entered. This value is set in the menu item „limit switch“. The previously set parameters are taken into account (unit, parameter, k-factor and the measuring range).

In the default setting the limits are not active. Display 2nd line: „OFF“

Alarm ON: Measurement for 12 seconds constantly greater than $1.0 \cdot \text{limit value}$

Alarm OFF: Measurement for 12 seconds constantly less than $0.95 \cdot \text{limit value}$

6. Maintenance

The DPC200 contains no wearing or consumable parts. Servicing is not required. On request, Arthur Grillo GmbH offers an annual calibration with factory certificate. For information, please contact:



Arthur Grillo GmbH	Phone: +49 21 02 - 47 10 22
Am Sandbach 7	Fax: +49 21 02 - 47 58 82
40878 Ratingen	E-Mail: info@grillo-messgeraete.de

7. Warranty

Warranty and liability claims for personal and property damage are excluded if they are caused by one or more of the following reasons:

- Improper use of the device.
- Improper installation, commissioning, operation and maintenance of the device.
- Unauthorized modifications to the device beyond the intended use.
- Disasters due to external influences and force majeure.

8. Troubleshooting

Description	Activity
Display does not show anything	Check electrical connection
Measurement stays zero	Function test with a slight pressure increase in measuring mode for differential pressure
Measuring error	Perform zeroing as described in chapter 4.5.
Error remains	Contact manufacturer

9. Disposal

Dispose of parts so as not to endanger human health or the environment. Follow the laws in the country of use for disposing of electronic components and devices during disposal.

10. Specifications

Measuring medium:	Air or inert gases	
Measuring principle:	Silicon diaphragm with spring and differential transformer	
Lowest span:	0...50 Pa	
Highest span:	0...4000 Pa	
Overpressure protection:	0.2 bar	
Static pressure:	max. 0.2 bar	
Pressure connections:	tubing 5 mm \varnothing or 6 mm \varnothing	
Enclosure:	UL 94 HB; Case polyamid, cover ABS	
Electrical connections:	cable inlet M16x1.5, screw terminal Electronic protection against reversed polarization	
Supply voltage:	10...30 Vdc; 24 Vac ($\pm 15\%$)	
Current consumption:	approx. 10 mA @ 10 Vdc, ca. 12 mA @ 24 Vdc	
Output:	0...10 V ($I_{\max} = 0.5 \text{ mA @ } 10 \text{ Vdc}$, $I_{\max} = 2 \text{ mA @ } 20 \text{ Vdc}$)	
Alarm output:	Open Collector, max. 30 V / 30 mA	
Display:	LCD-Display, 2 x16 characters	
Mode:	Measuring mode or controlling mode	
Controlling algorithm:	PI	
Setpoints:	2 setpoints adjustable within software, Setpoints are selectable with floating contact input	
Protection class:	IP 54 according EN 60529	
Ambient temperature:	-10...50 $^{\circ}\text{C}$	
Storage temperature:	-25...60 $^{\circ}\text{C}$	
Weight:	approx. 250 g	
Mounting:	vertical, position dependence by turning of 90 $^{\circ}$: approx. 25 Pa	
Interference / emission:	according EN 61000-6-2, EN 61000-6-3, CE mark	
Influences / limits:	Zero error:	$\pm 0.75 \%$
	Sum of linearity and hysteresis (depends on measuring range):	$\pm 0.5 \%$... $\pm 1 \%$
	Temperature drift, zero point:	$\pm 0.3 \%$ / 10 K
	Temperature drift, span:	$\pm 0.2 \%$ / 10 K

10.1 CE-labelling

As an electric device the DPC200 falls within the scope of the directive 2004/108/EG (EMV-directive). In the scope of the EMV-directive the following norms were applied:

DIN EN 61000-6-2:2006-03 Berichtigung 1:2011-06	Electromagnetic compatibility (EMC) - Part 6-2: Generic standards - Immunity for industrial environments
DIN EN 61000-6-3:2011-09	Electromagnetic compatibility (EMC) - Part 6-3: Generic standards - Emission standard for residential, commercial and light industrial environments

You can order the Declaration of Conformity at:

Arthur Grillo GmbH
 Am Sandbach 7
 40878 Ratingen
 Phone: +49 21 02 - 47 10 22
 Fax: +49 21 02 - 47 58 82
 E-Mail: info@grillo-messgeraete.de

11. Ordering information

Article	Item no.
Differential pressure controller DPC200 Measurement range: 0...50 Pa	2570
Differential pressure controller DPC200 Measurement range: 0...500 Pa	2572
Differential pressure controller DPC200 Measurement range: 0...1000 Pa	2574
Differential pressure controller DPC200 Measurement range: 0...2000 Pa	2576
Differential pressure controller DPC200 Measurement range: 0...4000 Pa	2578
Mounting set M-DS with screws, bleeders and 2m plastic tube (4 x 1,5 mm)	25110

Notes: